



## INSTALLATION GUIDE: **AWE 5.7L Dodge Durango**

**THIS GUIDE IS INTENDED FOR THE FOLLOWING PART NUMBERS:**

- 3020-32575 AWE Track Edition Exhaust for Dodge Durango 5.7 - Chrome Silver Tips
- 3020-33575 AWE Track Edition Exhaust for Dodge Durango 5.7 - Diamond Black Tips
- 3015-32575 AWE Touring Edition Exhaust for Dodge Durango 5.7 - Chrome Silver Tips
- 3015-33575 AWE Touring Edition Exhaust for Dodge Durango 5.7 - Diamond Black Tips
- 3815-11575 AWE Track-to-Touring Conversion Kit for Dodge Durango 5.7
- 3820-11575 AWE Touring-to-Track Conversion Kit for Dodge Durango 5.7

Welcome to the AWE family, and congratulations on your purchase of the AWE Exhaust system for the Durango.

Exquisite build quality and craftsmanship, coupled with industry leading performance, distinguish this exhaust system from all others.

\*For up to the minute fitment information, be sure to visit the AWE website. As always, AWE Performance Specialists are standing by for any questions, [right here](#).

# PARTS LIST (TRACK AND TOURING)



**INSPECT ALL PARTS PRIOR TO DISASSEMBLY OF VEHICLE; IF DAMAGED OR MISSING, PLEASE CONTACT THE PLACE OF PURCHASE IMMEDIATELY.**

Symbol	Part Number	Description	QTY
	G12	Dodge Durango WD 5.7L Resonated H-Pipe	1
	F19	Dodge Durango WD Hemi 392/SRT Hellcat Axle Tube Driver	1
	F20	Dodge Durango WD Hemi 392/SRT Hellcat Axle Tube Passenger	1
	E23	Ram 4th/5th Gen Rear Exit Dual Mw/cutout D/P Tip Outlet	2
	98093A648	Black-phosphate class 10.9 steel screw, flanged hex head, M10 x 1.50mm, 90mm long	4
	180300	AWE 3.0" Band Clamp, Stainless	4
	SEC75	3" Barrel Clamp (Bubble)	2
	3910-41010	Hardware kit for integrated clamp style exhaust tips	1
	3910-11012	AWE 1/2" split collar clamp kit: includes 9/64 allen wrench and two 1/2" collar clamps	1
<b>Track Systems Only</b>			
	F23	Dodge Durango WD Hemi 392/SRT Hellcat Track Rear Driver	1
	F24	Dodge Durango WD Hemi 392/SRT Hellcat Track Rear Passenger	1
<b>Touring Systems Only</b>			
	F21	Dodge Durango WD Hemi 392/SRT Hellcat Touring Rear Driver	1
	F22	Dodge Durango WD Hemi 392/SRT Hellcat Touring Rear Passenger	1
<b>Chrome Tips Only</b>			
	180006	5.00" OD x 3.00" ID, Slash Cut, Chrome Silver, AWE logo, Integrated Clamp	2
<b>Black Tips Only</b>			
	180007	AWE black chrome 5" slash cut tip	2

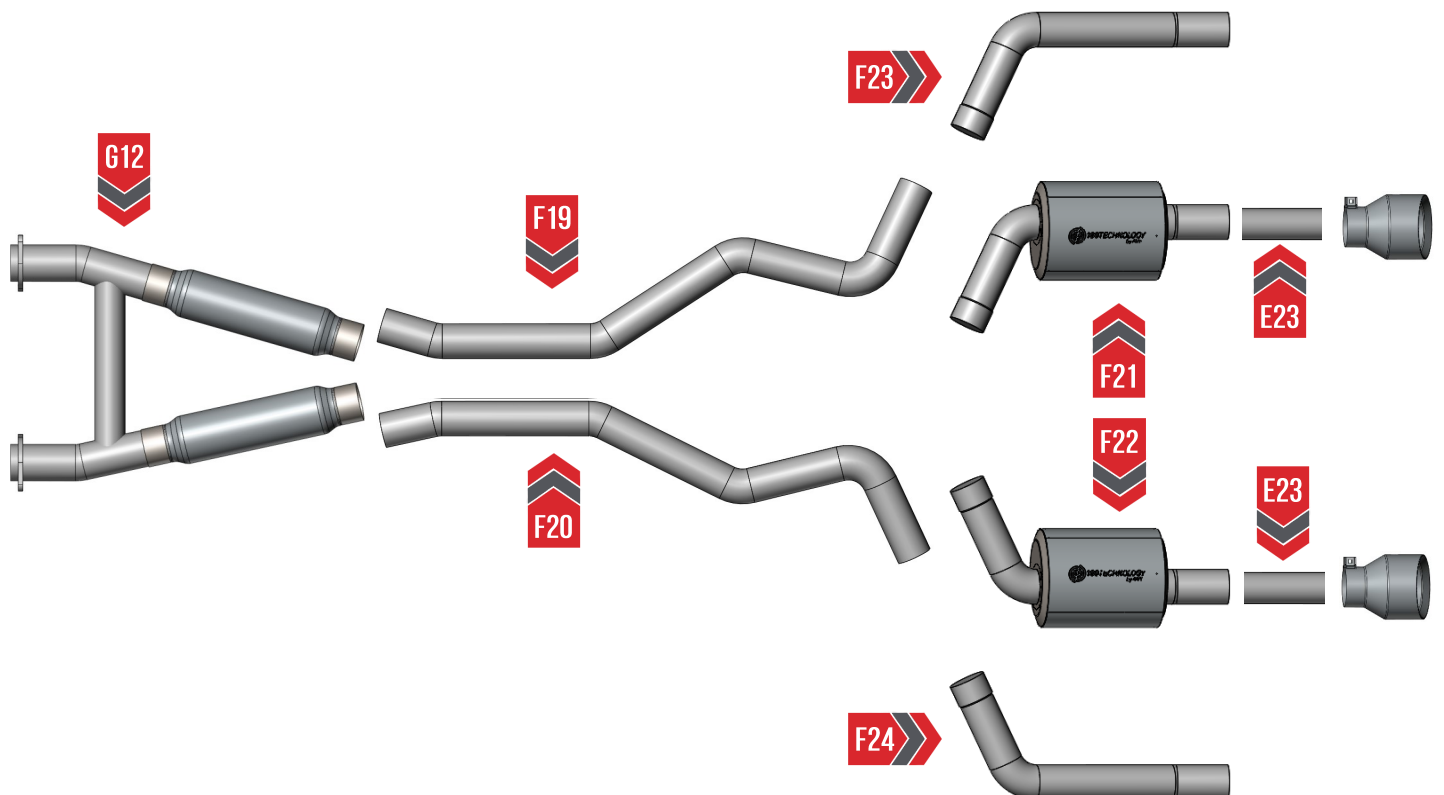



**NOTE:** Always refer to the manufacturer's service manual for precise torque specifications on all OEM fasteners.



**CAUTION:** The exhaust may be **VERY HOT** — allow adequate time for the system to cool down before disassembly. Severe burns and injury will occur if skin comes into contact with a hot exhaust system.

## STEP 1

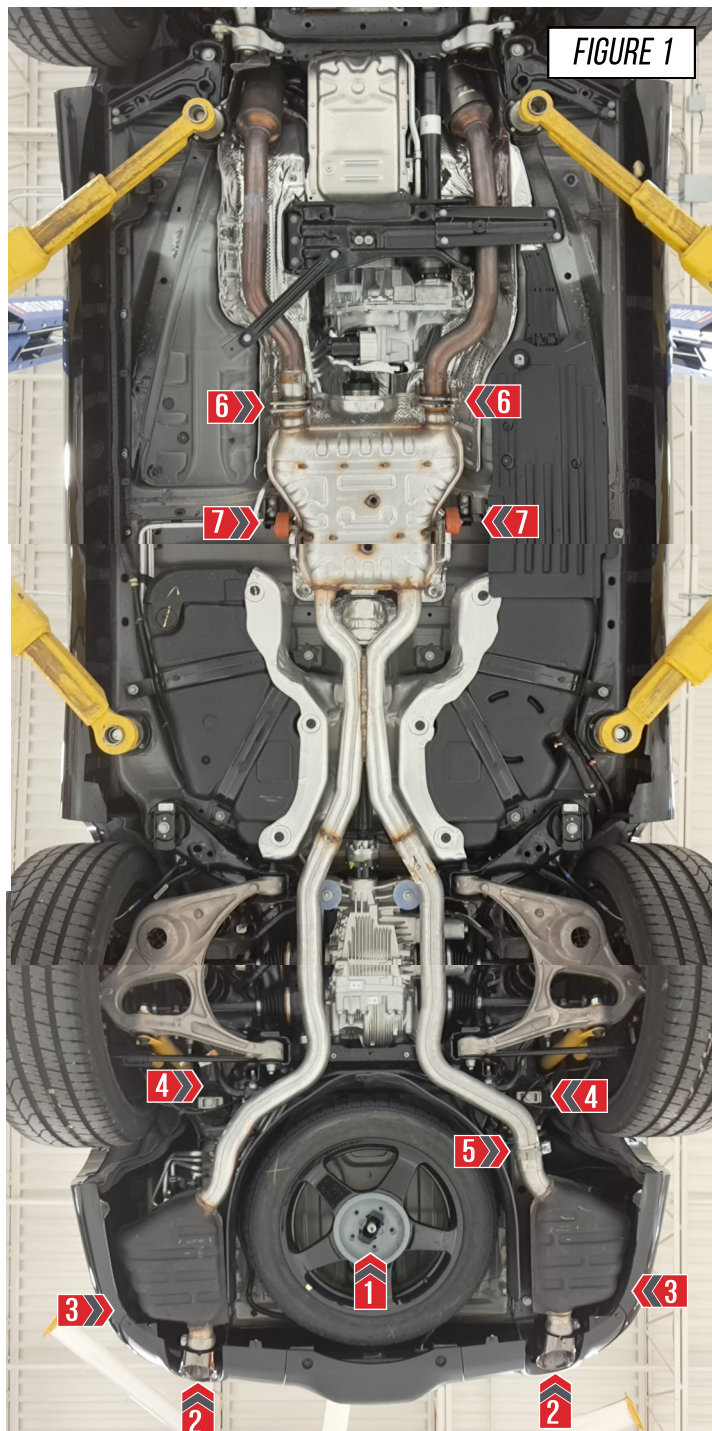

Start by removing the OEM Durango exhaust by following these steps, shown in **Figure 1**.

1. Remove spare tire and heat shield around tire.
2. Remove the OEM tips.
3. Remove the 2 OEM rear hangers, above the mufflers.
4. Remove the 2 OEM axle hangers.
5. Loosen the exhaust clamp, now you will be able to carefully remove the driver side muffler from the vehicle.
6. Remove the OEM hardware on both flanges.
7. Remove the 2 front hangers.
8. Remove the OEM exhaust from the vehicle.

**NOTE:** The DS muffler may take force or rotation to remove it from the OEM exhaust.

**NOTE:** All 6 rubber OEM exhaust hangers will be used with your AWE exhaust. Do not mix up the original locations of the 6 hangers.

## STEP 2

Start installing your AWE exhaust by placing the 2 OEM hangers onto the H-pipe, as shown in **Figure 2-1**. Install the H-pipe onto the OEM down pipes, using the bent hanger bar pointing up (A) as a guide for correct alignment, next place 2 of the provided exhaust clamps (B), as shown in **Figure 2-2**.

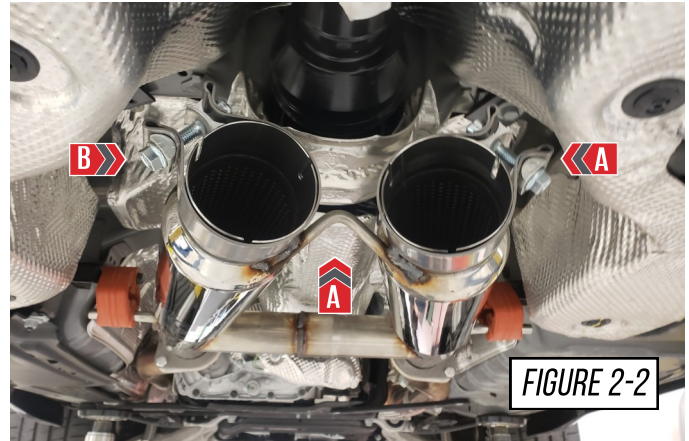
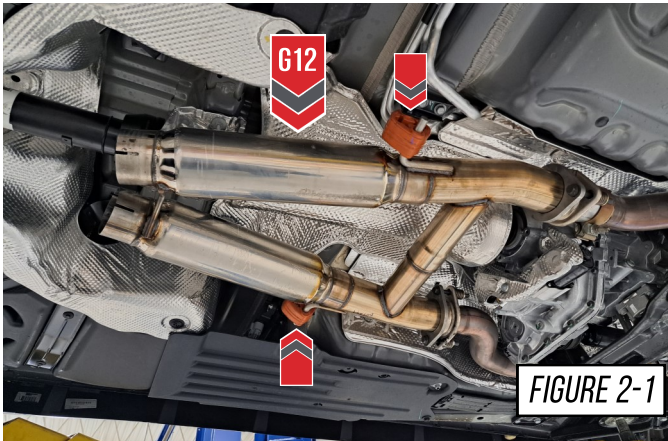

## STEP 3

The flange is connected using the 2 per side, supplied bolts and the 2 per side, OEM springs and flange nuts.



The bolts are properly tightened when the flange nut is bottomed out on the bolt. Over tightening the bolt will strip it out.

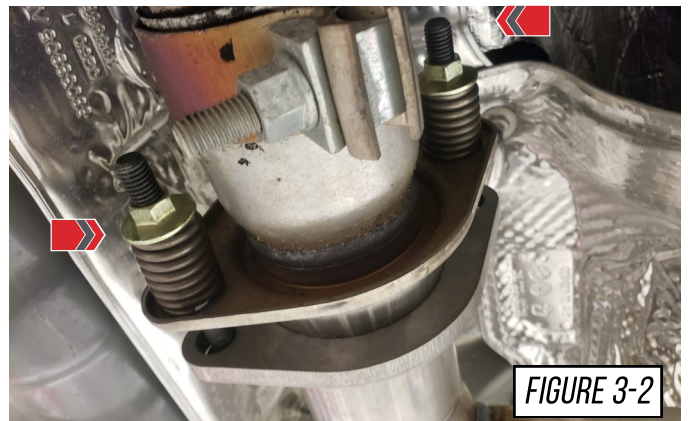
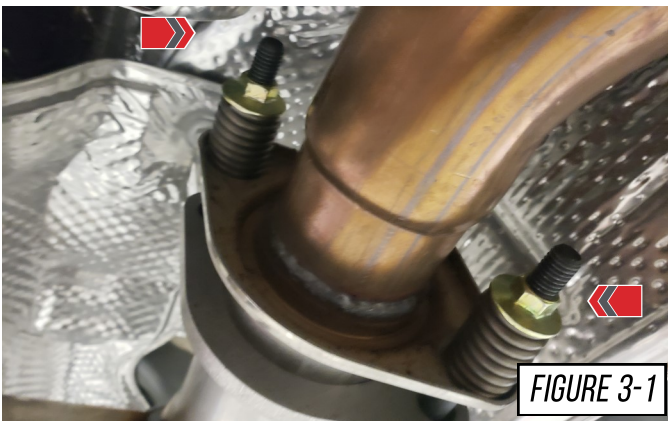

## STEP 4

If the H-Pipe is not aligned correctly in the OE tunnel, you may adjust the OE passenger side flange (A) by loosening the OE clamp (B) as shown in **Figure 4**.

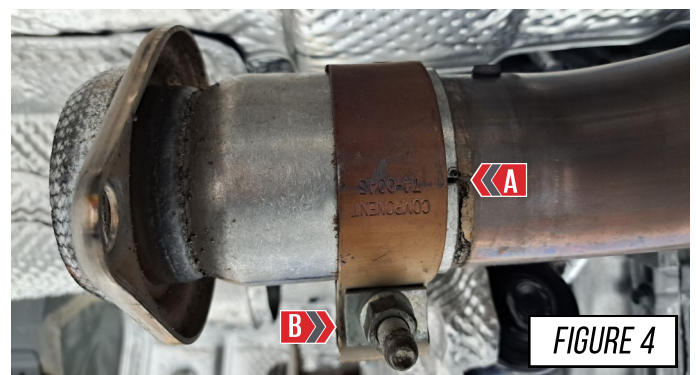

## STEP 5

Gather your 2 AWE axle tubes. Note the passenger (**F20**) tube has a longer straight section at the end, as shown in **Figure 5**.

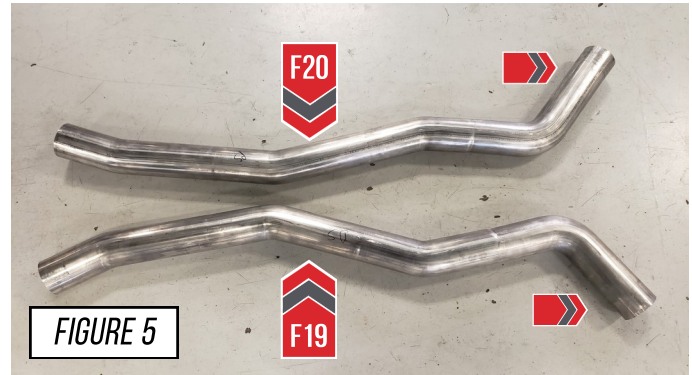

## STEP 6

It is crucial to install each section and exhaust band clamps correctly to prevent loose joints, exhaust leaks and rattles.

**Arrow A** shows the expanded tube and the preinstalled exhaust clamp being brought up to the corresponding tube.

**Arrow B** shows the overlapping tube installed correctly over the corresponding tube.

**Arrow C** shows the exhaust band clamp being brought to the edge of the expanded tube.



### NOTES:

- **Do not** fully torque any exhaust clamp until the entire exhaust has been installed and adjusted.
- Torque specification is a **minimum** of 60 ft/lbs

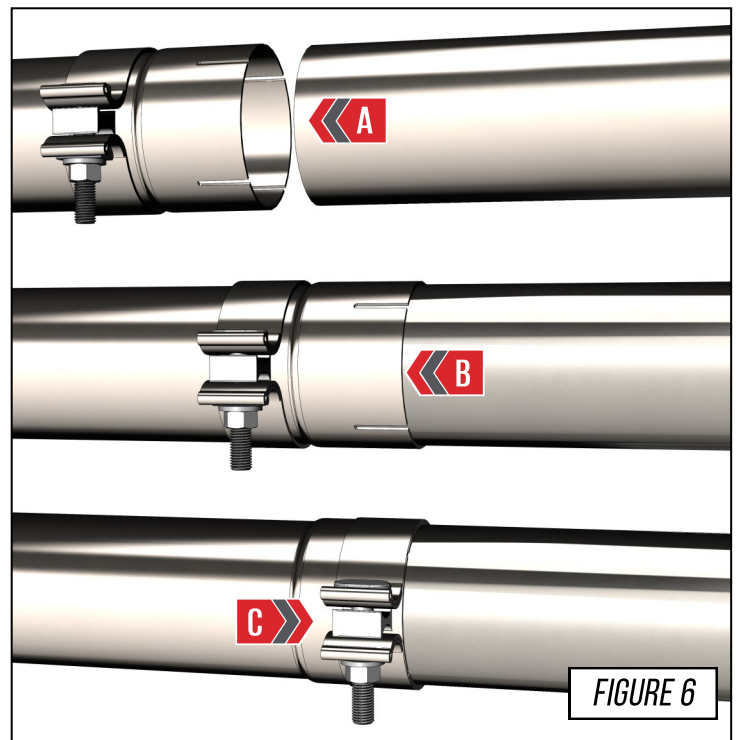

## STEP 7

Gather your AWE **DS** mid pipe and **DS** rear section. The axle pipe has no hangers, for ease install both tube sections, as shown in **Figure 7**, with the supplied clamp at (**A**) and the OEM hangers at (**B**).

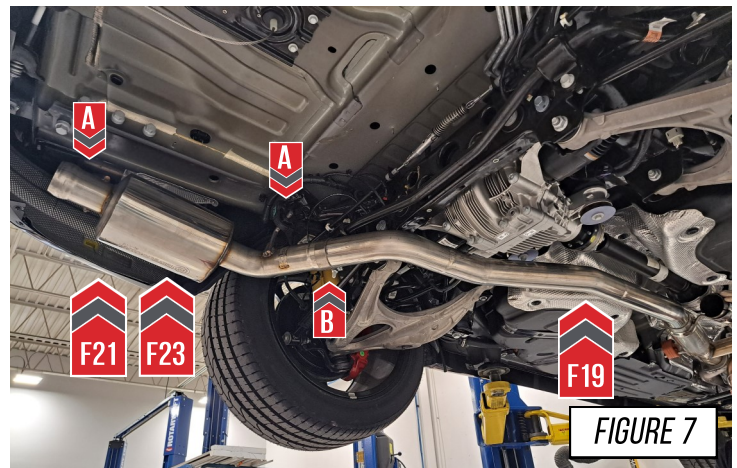

## STEP 8

Gather the AWE **PS** mid pipe and **PS** rear section. The axle tube has no hangers, for ease install both tube sections, as shown in **Figure 7**, with the supplied clamp at **(A)** and the OEM hangers at **(B)**.

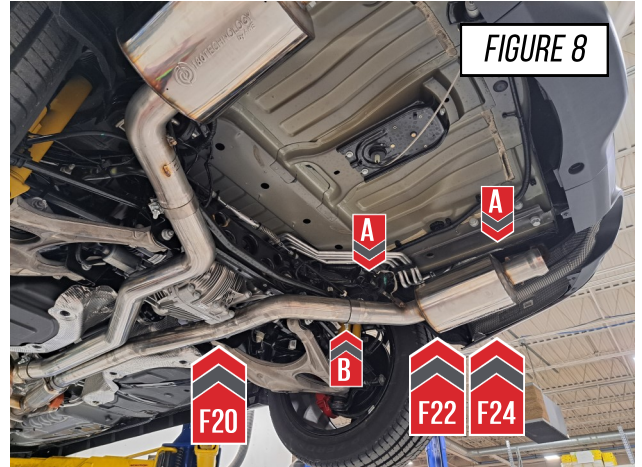

## STEP 9

Install the 2 AWE rear tip outlet tube (**E23**) using the supplied ball clamps, as shown in **Figure 9**.

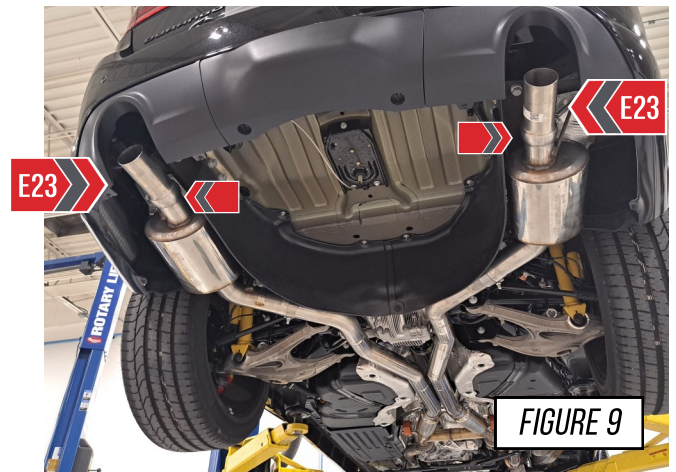

## STEP 10

Install the AWE tips and hardware onto the AWE exhaust, do not fully tighten ball clamps at this point.



Use anti-seize in the threads of the clamps.



## STEP 11

To install the exhaust tips with integrated clamps, first, attach the exhaust tip in the proper orientation onto the exhaust outlet tube.

Insert one of the carriage bolts from the hardware kit (**3910-41010**) through the tab on the exhaust tip and thread on one of the corresponding nuts.

Using anti-seize on the bolt threads will help installation and prevent breakage of hardware.

 This exhaust system only has 2 exhaust tips while the integrated clamp kit has enough hardware for our 4 tip exhaust systems. You will have 2 sets of hardware left over that will not be used.

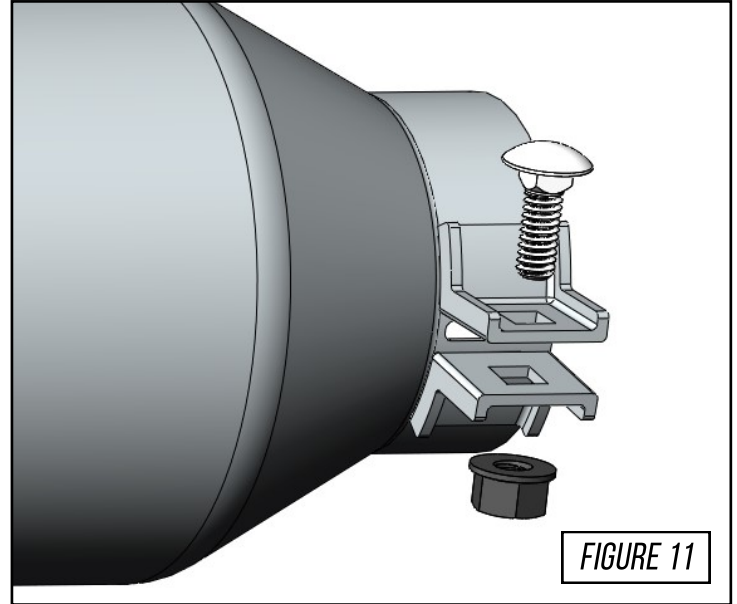

## STEP 12

For the rear sections, hanger bar collar clamps are provided to prevent side to side movement of the exhaust system. After sliding the exhaust hanger bar through the OEM grommet, install the collar clamp on the outside end of the bar as shown in **Figure 12-1**, in the locations shown in **Figure 12-2**.

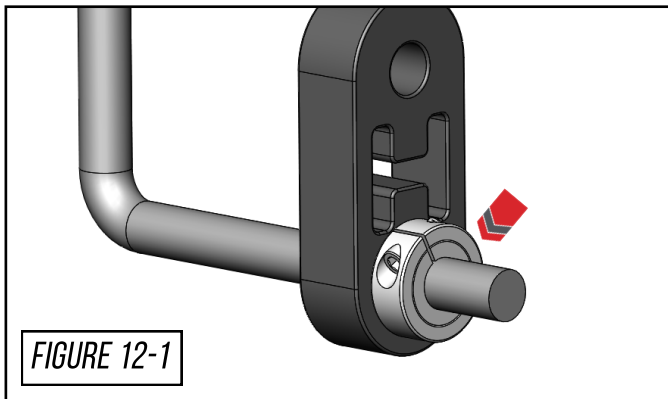

## STEP 13

Make your final adjustments to the tips to ensure they are in a position you like. Once the desired positioning is achieved work from the front of the car to the back, tightening all the clamps fully and ensuring there is proper clearance of the chassis, and braces.

It is now recommended to drive the car to allow the exhaust to heat cycle after all clamps and tips are fully tightened.



At this point the exhaust will be very hot, allow to cool before work continues.

Check the tips for correct alignment, adjust as needed.



Don't forget to see the next page for any troubleshooting needs!



# ENJOY!





# TROUBLESHOOTING

Issue	Solution
Exhaust is not fitting correctly	Most fitment issues are due to improperly adjusted exhaust. This includes tip fitments and rattling due to chassis contact. Check out our <a href="#">fitment guide</a> for more installation tips.
Wrong or missing parts	Double check the parts list for your system and compare them with what you received. Fill out our contact form, found below and let us know what parts you need.

# CARE

Once installed properly, your AWE exhaust will provide years of trouble-free performance.

The exhaust volume and sound will settle with usage; 800-1000 miles is required to break-in new exhaust systems.

Also, please note that the rear **180Technology®** resonator has a small drain hole to allow condensation to escape. Water drops from this area are normal.

Periodic cleaning of exhaust tips is necessary to maintain proper finish, especially in areas prone to road salt and caustic deicing solutions. Use a mild soap and water solution or car wax to clean the finish. Avoid using abrasive polishes, as they can scratch the finish.

Any questions or comments,  
please do not hesitate to contact us:

**AWE**  
215-658-1670  
[CONTACT FORM](#)

# WARRANTY

Up-to-date warranty information is found [HERE](#).