

V0013000

THIRTEEN



CFR ANGLE KIT
INSTALLATION INSTRUCTIONS:
2009-PRESENT NISSAN 370Z Z34
2008-2013 INFINITI G37 V36
PART NUMBERS:
V00-AKNS-0400

We recommend that installation of all Voodoo13 parts be completed by a professional who is experienced in suspension tuning. With proper installation and maintenance, Voodoo 13 suspension products will provide exceptional performance and durability. For any questions, please contact Voodoo 13 immediately. We thank you for choosing Voodoo 13 for your suspension tuning needs!

NEED HELP?

Our representatives are here to help you with any questions concerning the operation of this product.

CALL 480-889-0812

Monday thru Friday 8:30am to 5:30pm MST

RECOMMENDED TOOLS AND SUPPLIES

- General Mechanics Tool Set
- Torque Wrench
- Anti-Seize Lubrication
- Welding Machine

PART BREAKDOWN

NOTE: For any OE hardware please refer to OEM service manual for torque specifications. For all included hardware please torque to specifications shown below.

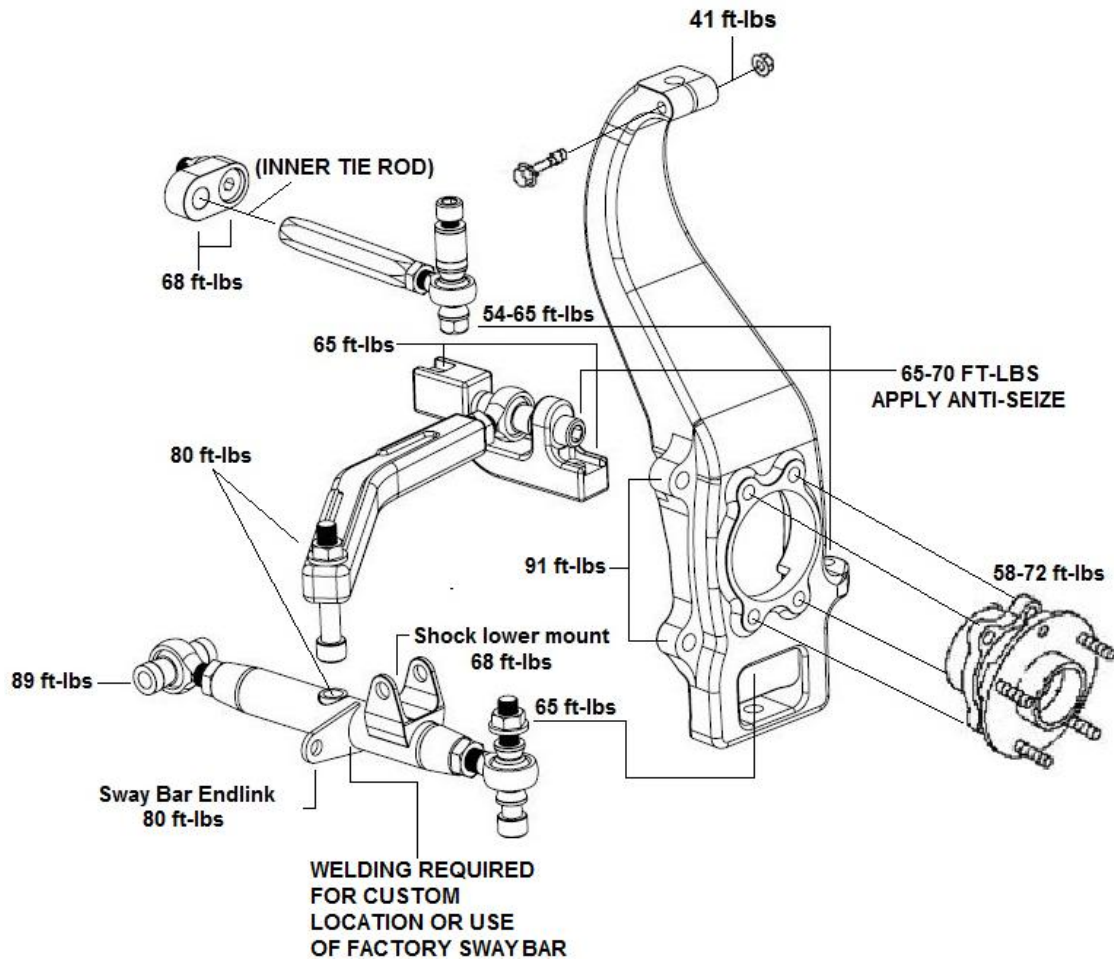

TRANSVERSE LINK

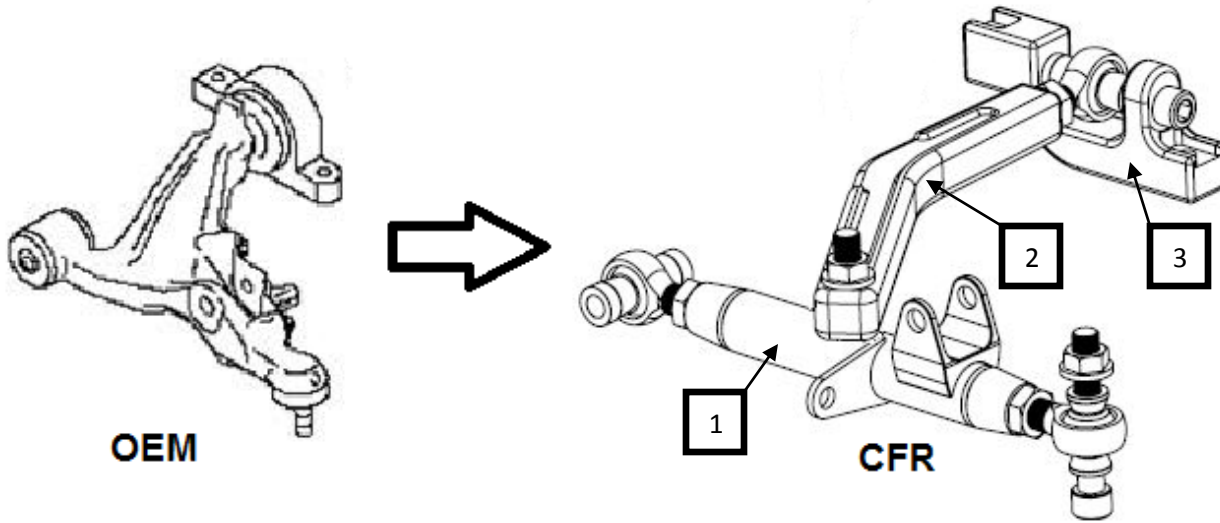

PARTS BREAKDOWN CONTINUED

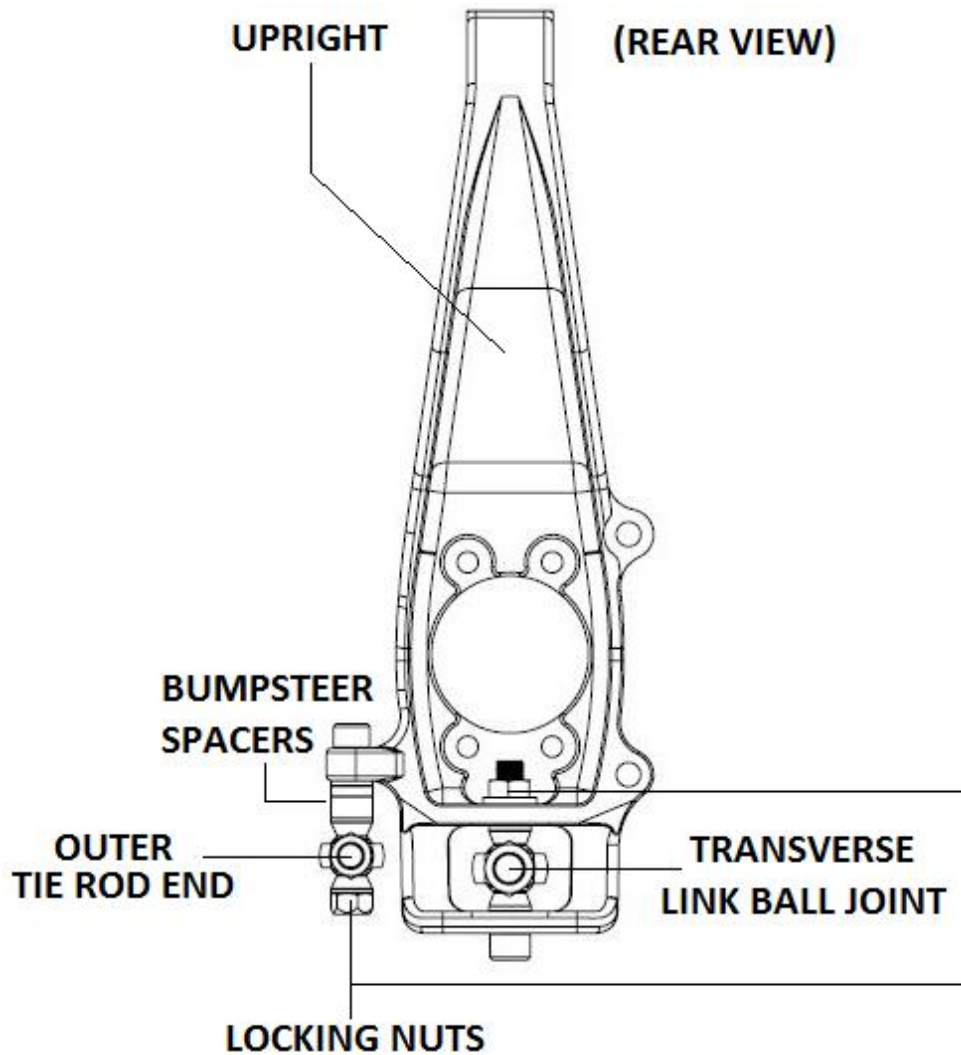

INSTALLATION PROCEDURE

Step 1: Lift the vehicle to a safe height using the recommended factory lift points to work underneath the rear suspension. Ensure to place safety jack stands where recommended by Nissan before anyone goes underneath the car (unless using a vehicle lift with safety locks).

Step 2: Remove the factory lug nuts in order to take off the front wheels.

Step 3: Remove the 2 bolts securing the brake caliper on to the upright. Then secure the brake caliper from damaging the brake lines and the ABS sensor cable. Then remove 2 bolts holding the brake line bracket to the front of the upright. NOTE: Custom location required for brake lines and ABS sensor cables. RECOMMENDED: Switch to Stainless Steel Brake lines for easier mounting.

Step 4: Remove the brake rotor to gain access hub. Then remove the 4 bolts that secure the hub to the upright. Then bolt them to the new CFR upright to 58-72 ft-lbs.

Step 5: Next the upright's pinch point needs to be unbolted to release the ball joint's shank from the upper link. Pins are needed to be removed to gain access to the slotted nut.

Step 6: Remove the tie rod from the steering rack and the upright. To gain access to the inner tie rod, the boot needs to be removed. Next the ball joint from the transverse link (lower control arm) that is attached to the lower part of the upright needs to be removed. Pins are needed to be removed to gain access to the slotted nut.

Step 7: The lower part of the shock needs to be unbolted from the transverse link(lower control arm) as well as the end link.

Step 8: 3 bolts are left that are securing the transverse link to the front cross member. Unbolt and extract the transverse link from the front cross member.

Step 9: Bolt the two main pieces (#1 & #2) CFR lower control arm together. Just tighten the nut enough to hold for the rest of the installation. Torque the nut after the rest of the suspension is installed. Install the lower control arm aluminum bracket (#3) and torque the two bolts to **65 ft-lbs**. Refer to the Transverse link diagram.

Step 10: Once removed, adjust the CFR transverse link to your preferred setup . The rod ends on the welded lower tube control arm(#1) can adjust camber and track width. The aluminum arm(#2) can adjust caster. Once adjustments are made, install the CFR transverse link onto the front cross member. The welded lower tube arm's inner end must be torqued to 89 ft-lbs to the front cross member. Then grab the 5/8-18 socket bolt, anti-seize lubricate must be used, and follow the diagram for the installation for

securing the rod end of the aluminum arm(#2) to the aluminum bracket(#3). Torque to 65-70 ft-lbs. *Ensure to at least one diameter of the rod end is threaded into the part.*

Step 11: Then attach the lower mount of the shock with the factory bolt to the transverse link bracket. Torque to **68 ft-lbs.**

Step 12: The other end that replaces the factory ball joint will be torqued to **65 ft-lbs** to upright. Refer to the upright diagram. Then bolt the upper link to the pinch point of the upright. Torque to **41 ft-lbs.**

Step 13: Take the inner tie rod end and thread them into the supplied offset spacer. The bolt supplied should be used to secure offset spacer into the steering rack. Torque them to **68 ft-lbs.**

Step 14: The supplied outer tie rod hex should then be threaded onto the inner tie rod. The kit should include bumpsteer spacers for adjustments. Torque the new tie rod to the upright to **54-65 ft-lbs.**

Step 15: The end link can finally be attached to the new CFR transverse link. NOTE: End link tab must be welded. Torque to **80 ft-lbs.**

Step 16: The rotor can be installed to the hub. The brake caliper can be installed next. The 2 bolts that secure them onto the upright require **91ft-lbs.**

Step 17: Torque the CFR transverse link that's holding part #1 and #2 to **80 ft-lbs.**

Step 18: Ensure all jam nuts on the transverse link and the tie rod are secure.

Step 19: Reinstall the wheels on the hub and torque the lug nuts factory specs via service manual.

Step 20: Lower vehicle safely back to the ground and perform a vehicle alignment. You are finished!

ROD END ADJUSTMENT GUIDELINES

When adjusting rod end to desired position, adjust so that the rod end and adjuster have approximately the same amount of thread showing. Always use the jam nuts to secure the rod end and adjuster. Never tighten the rod end into the adjuster or the adjuster in the lower control arm as a jamming mechanism.

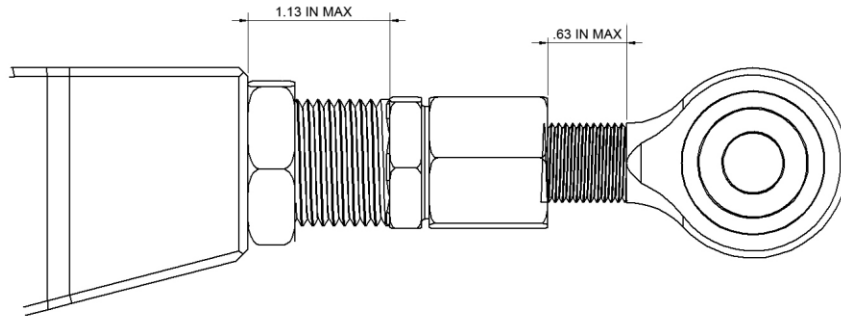

CORRECTLY ADJUSTED

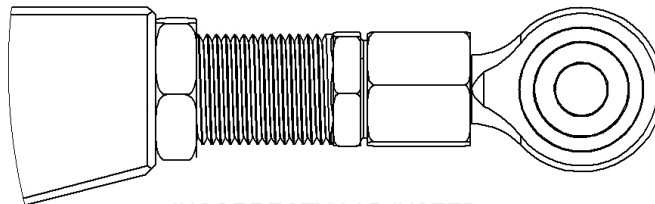

INCORRECTLY ADJUSTED
INSUFFICIENT THREAD ENGAGEMENT ON ADJUSTER

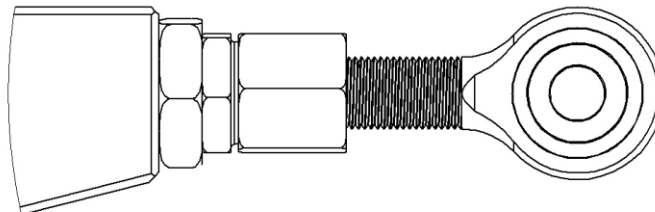

INCORRECTLY ADJUSTED
INSUFFICIENT THREAD ENGAGEMENT ON ROD END

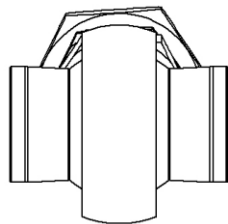

CORRECTLY POSITIONED

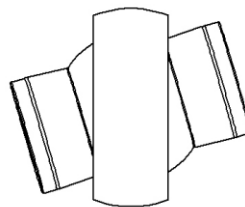

INCORRECTLY POSITIONED
TOO MUCH STATIC ROD END MISALIGNMENT

WARRANTY

All products sold are subject to the following warranty:

Voodoo 13 offers a Limited Lifetime Warranty for our products to the original retail consumer against defects and workmanship when used on light truck and car applications under normal operating conditions. This warranty does not apply to parts that have been improperly installed or wearable items such as, but not limited to, worn bushings or bearings unless proven to be defective from the manufacturer.

Exterior finish on all Voodoo 13 products is not considered a valid warranty; consumers are responsible for the maintenance of paint, anodize or raw metal finish.

The consumer will be responsible for the removal and freight costs both to and from the Distributor from which the product was originally purchased. Proof of purchase and product registration through the Voodoo 13 website is mandatory in order to receive warrantee replacement; original invoice from the Distributor from which the product was purchased must accompany the product in question for warrantee.

Voodoo 13 has the right to refuse a warrantee claim if procedures are not met by the original consumer. All returns must have an R.M.A. approval from Voodoo 13 prior to shipping direct to the Voodoo 13 facility. Exclusions from this warranty are sales outside of the United States, the finish, dents, rust, or any condition caused by abnormal use or neglect.

WARNING

High performance parts. For off-road use only. Installation should be carried out by a qualified facility. Improper use or installation may result in injury or death.



VOODOO13
115 N Sunway Drive
Gilbert, AZ 85233
Ph: 480.889.0812
Fax: 480.829.8103
www.VOODOO13USA.com