

THE INFORMATION CONTAINED IN THIS DRAWING IS THE SOLE PROPERTY OF
 ADVANCED ENGINE MANAGEMENT, INC. ANY REPRODUCTION IN PART OR WHOLE WITHOUT
 THE WRITTEN PERMISSION OF ADVANCED ENGINE MANAGEMENT, INC. IS PROHIBITED.

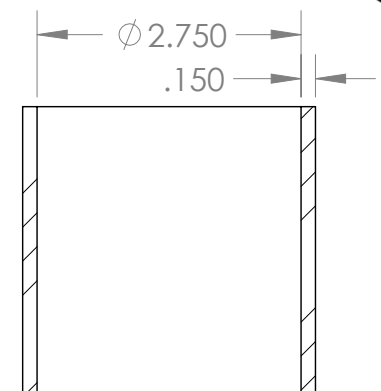
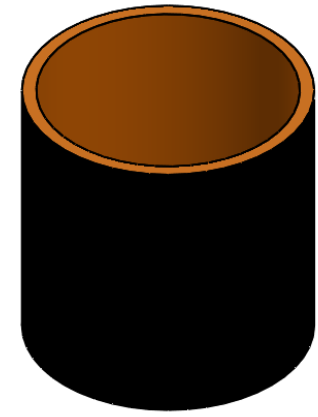
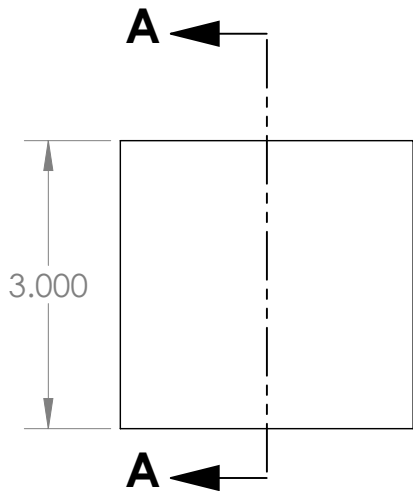
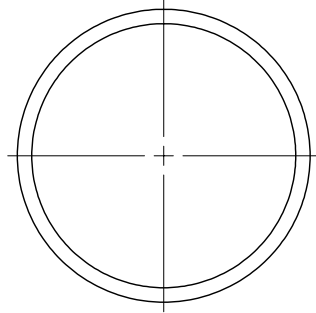

SECTION A-A

UNLESS OTHERWISE SPECIFIED
 DIMENSIONS ARE IN INCHES
 TOLERANCES ARE:
 ±.X ±.XX ±.XXX
 ±.06 ±.01 ±.005
 ANGLES ±1°
 CONCENTRICITY .010 T.I.R.

MATERIAL
 REINFORCED SILICON RUBBER, COUPLER

FINISH
 BLACK

PART
 VOLUME 4.10

CAD GENERATED DRAWING,
 DO NOT MANUALLY UPDATE
 DO NOT SCALE DRAWING



TITLE
 HOSE, SILICONE 2.75X3" BLK

SIZE A	DWG. NO. AEM-5-275 (ONLINE)	REV. A
-----------	--------------------------------	-----------

SCALE 1:2	<input type="radio"/> UK <input checked="" type="radio"/> USA	SHEET 1 OF 1
--------------	---	--------------