



## ***advanced FLOW engineering***

### **Instruction Manual**

P/N: 77-43042

### **SCORCHER HD POWER MODULE**

Make: Ford  
Make: Ford  
Make: Ford  
Make: Ford

Model: F-250 Super Duty  
Model: F-350 Super Duty  
Model: F-450 Super Duty  
Model: F-550 Super Duty

Year: 2020  
Year: 2020  
Year: 2020  
Year: 2020

Engine: V8-6.7L (td) Powerstroke  
Engine: V8-6.7L (td) Powerstroke  
Engine: V8-6.7L (td) Powerstroke  
Engine: V8-6.7L (td) Powerstroke



**THIS IS A HIGH-PERFORMANCE PRODUCT:** Do not use this product until you have carefully read the following agreement and installation instruction. This sets forth the terms and conditions for the use of this product. The installation of this product indicates that the BUYER has read and understands this agreement and accepts its terms and conditions.

**DISCLAIMER OF WARRANTY AND LIMITATION OF LIABILITY:** Advanced FLOW Engineering, Inc. (also known as aFe or aFe POWER) and its successors, distributors, jobbers, and dealers (hereafter “SELLER”) shall in no way be responsible for the product’s improper use and service. It is the installer’s responsibility to check for proper installation and if in doubt, contact the manufacturer. The SELLER assumes no liability regarding the improper installation or misapplication of its products. BUYER acknowledges it has had the opportunity to fully inspect the product. Accordingly, BUYER acknowledges that the product is being sold in “AS IS/WHERE IS” condition. SELLER shall not be held liable for special, indirect, incidental or consequential damages of any nature with respect to the products (including, without limitation, lost profits, lost sales, loss of production, property damage, personal injury or loss or damage resulting from interruption or failure in operation of the products) and BUYER hereby expressly waives and disclaims all such liability claims. The BUYER acknowledges and agrees that the disclaimer of liability contained herein is a material term of the sale of the product and, to the fullest extent permitted by law, BUYER shall defend, indemnify and hold SELLER harmless from any and all claims, demands, causes of action, controversies, liabilities, fines, losses, costs and expenses (including, but not limited to attorneys’ fees, expert witness expenses and litigation expenses) arising from or related to SELLER’s products.

**Before proceeding with the installation:**

- Please read the entire instruction manual before proceeding.
- Ensure all components listed are present.
- If you are missing any of the components, call customer support at 951-493-7185.
- Ensure you have all necessary tools before proceeding. Do not attempt to work on your vehicle when the engine is hot.

**Emission Disclaimer:** This product is not currently CARB exempt and is not available for purchase in California or for use on any vehicle registered with the California Department of Motor Vehicles.



Label	Qty.	Description	Part Number
A	1	Module	R77-43042
B	1	LED Switch	05-70029
C	2	Velcro (2" Inches)	05-01244
D	4	Cable Ties	05-60167





# SLEEP MODE

Figure A

## Refer to Figure A for Step 1

Step 1: Before installing your aFe POWER module, you will have to place your vehicle's ECU in sleep mode. In order to do this, you will need to do the following:

- If the engine is cold: open the hood, close the doors, lock the car and wait 30 seconds.
- If the engine is warm: open the hood, close the doors, lock the car and wait 20 minutes.
- If the engine is warm and you can't wait 20 minutes: disconnect the battery.

 **Note: Do NOT open doors or start vehicle while one of the sensors is disconnected. This could create a check engine light**



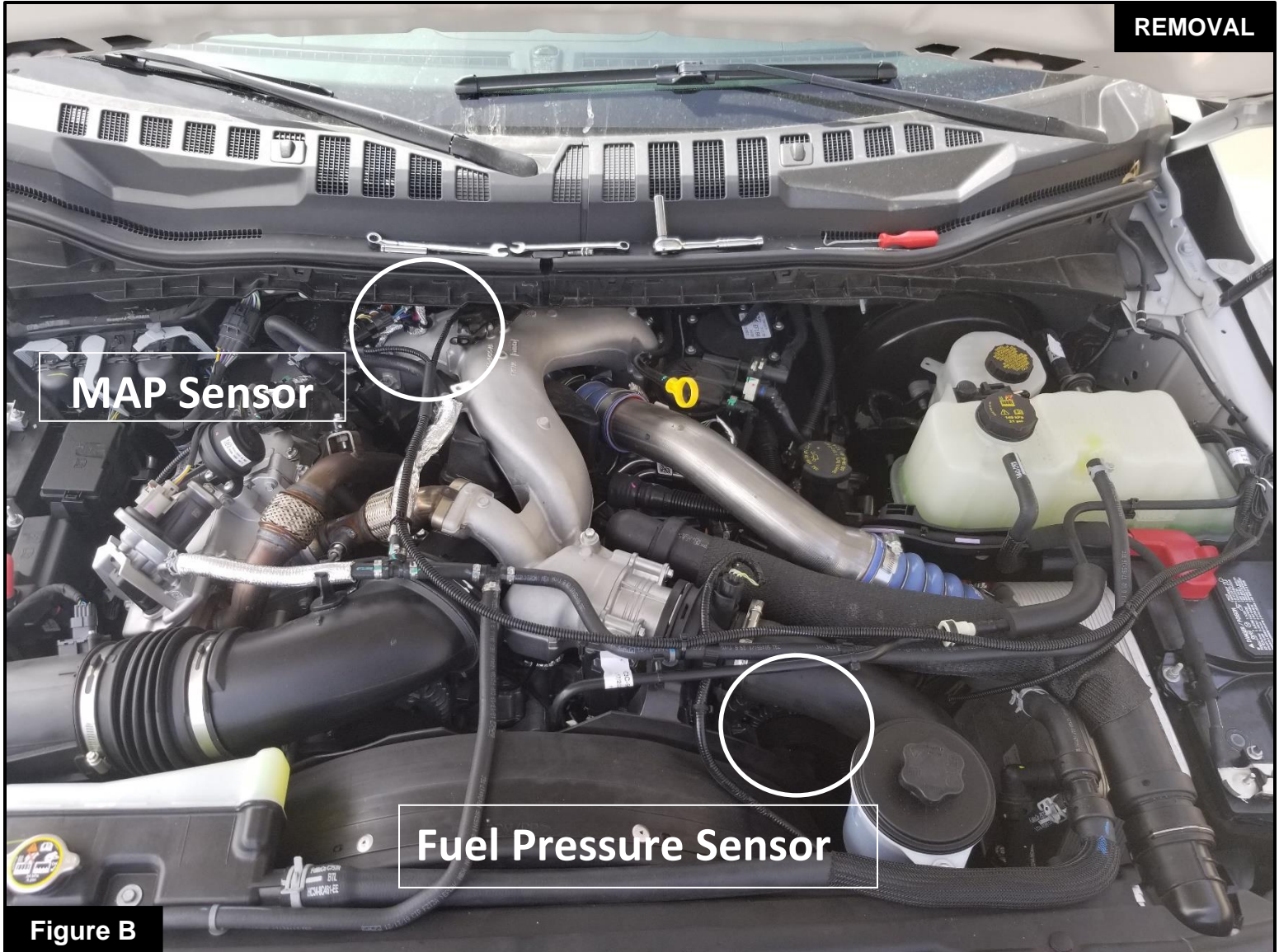

**Refer to Figure B for Steps 2-3**

Step 2: Locate the MAP sensor. The MAP sensor is below the black metal shield on top of the intake manifold.

Step 3: Locate the fuel pressure sensor. It is below the coupling on the intercooler tube, at the end of the common fuel rail. The common fuel rail runs alongside the valve cover on the driver side.

**Figure C****Refer to Figure C for Step 4**

Step 4: Remove the small black metal shield over the MAP sensor. This will reveal the connector for the MAP sensor.



**Figure D****Refer to Figure D for Steps 5-6**

Step 5: Locate and disconnect the MAP sensor by pressing down on the locking tab and sliding the connector out of the sensor.

Step 6: Locate the MAP sensor jumper harness on the aFe POWER harness. This is the longer jumper harness with a small rectangular connector. Plug the female connector of the aFe POWER harness to the MAP sensor, then take the male connector of the aFe POWER harness and connect it to the female connector of the engine harness.

**Figure E****Refer to Figure E for Step 7-8**

Step 7: Check with the pictures to make sure the connectors are fully seated.

Step 8: Reinstall the metal dust cover.



**Make sure that the connections are fully engaged and not reversed. Usually, connectors make a snapping sound when fully engaged.**

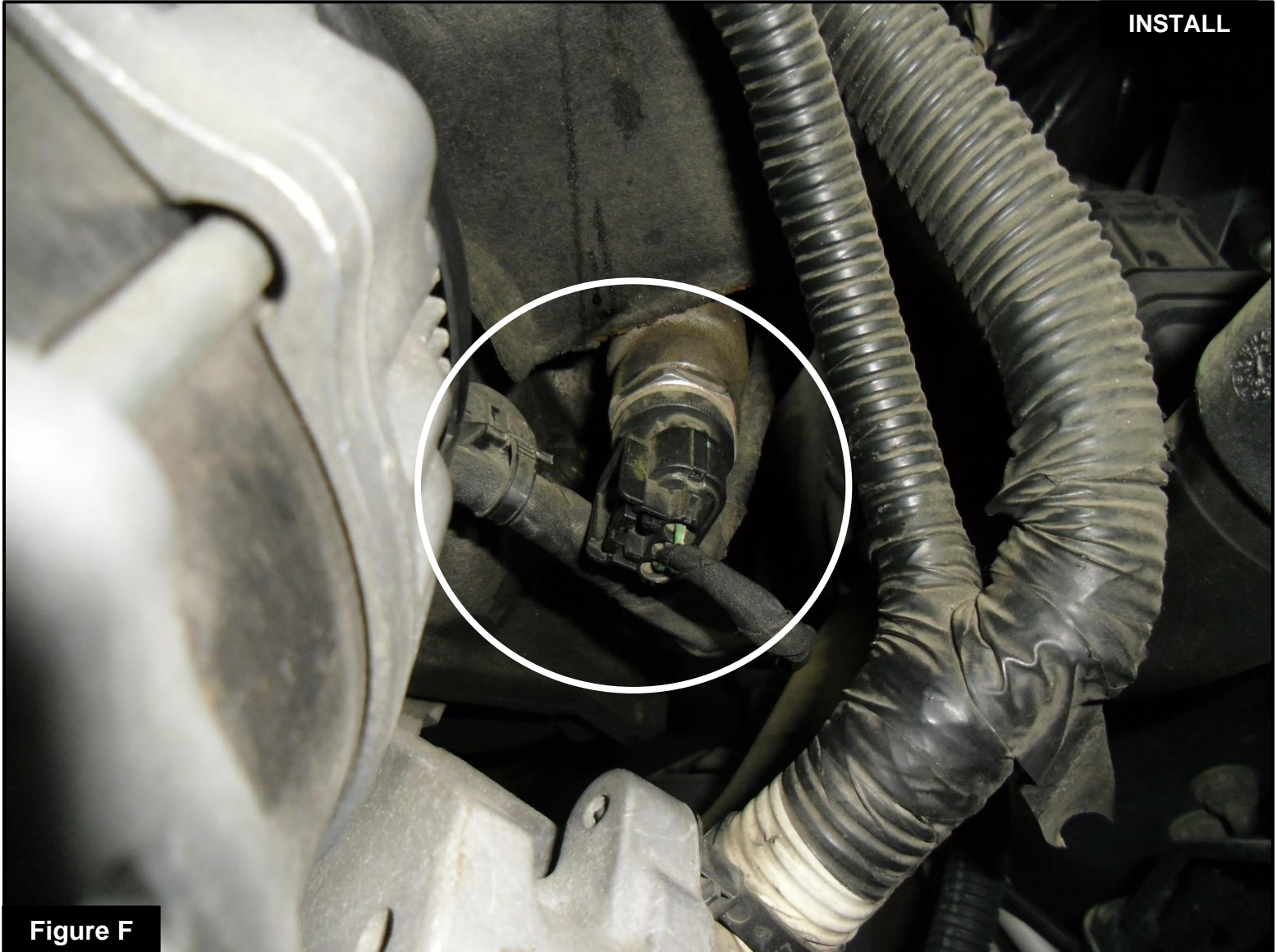

**Figure F****Refer to Figure F for Steps 9-10**

Step 9: Locate and disconnect the fuel pressure sensor connector by pressing down on the locking tab and sliding the connector out of the sensor.

Step 10: Locate the fuel pressure sensor jumper harness on the aFe POWER module. This is the shorter harness with a white label. Plug the female connector of the module to the stock fuel pressure sensor, then take the male connector of the module and connect it to the female connector of the engine harness.

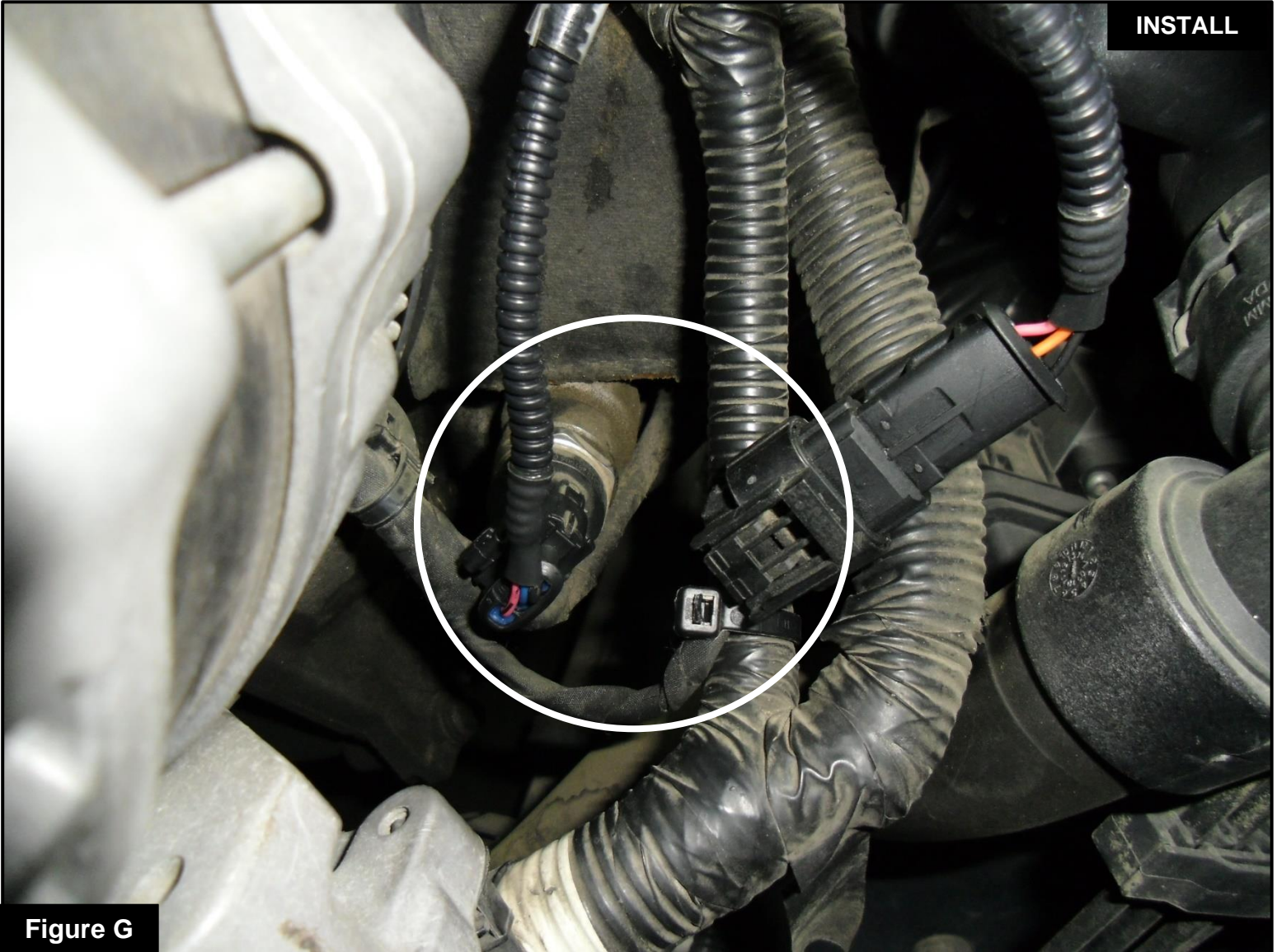

Figure G

**Refer to Figure G for Step 11**

Step 11: Check with the picture to make sure the connectors are correctly seated.



Make sure that the connections are fully engaged and not reversed. Usually, connectors make a snapping sound when fully engaged.

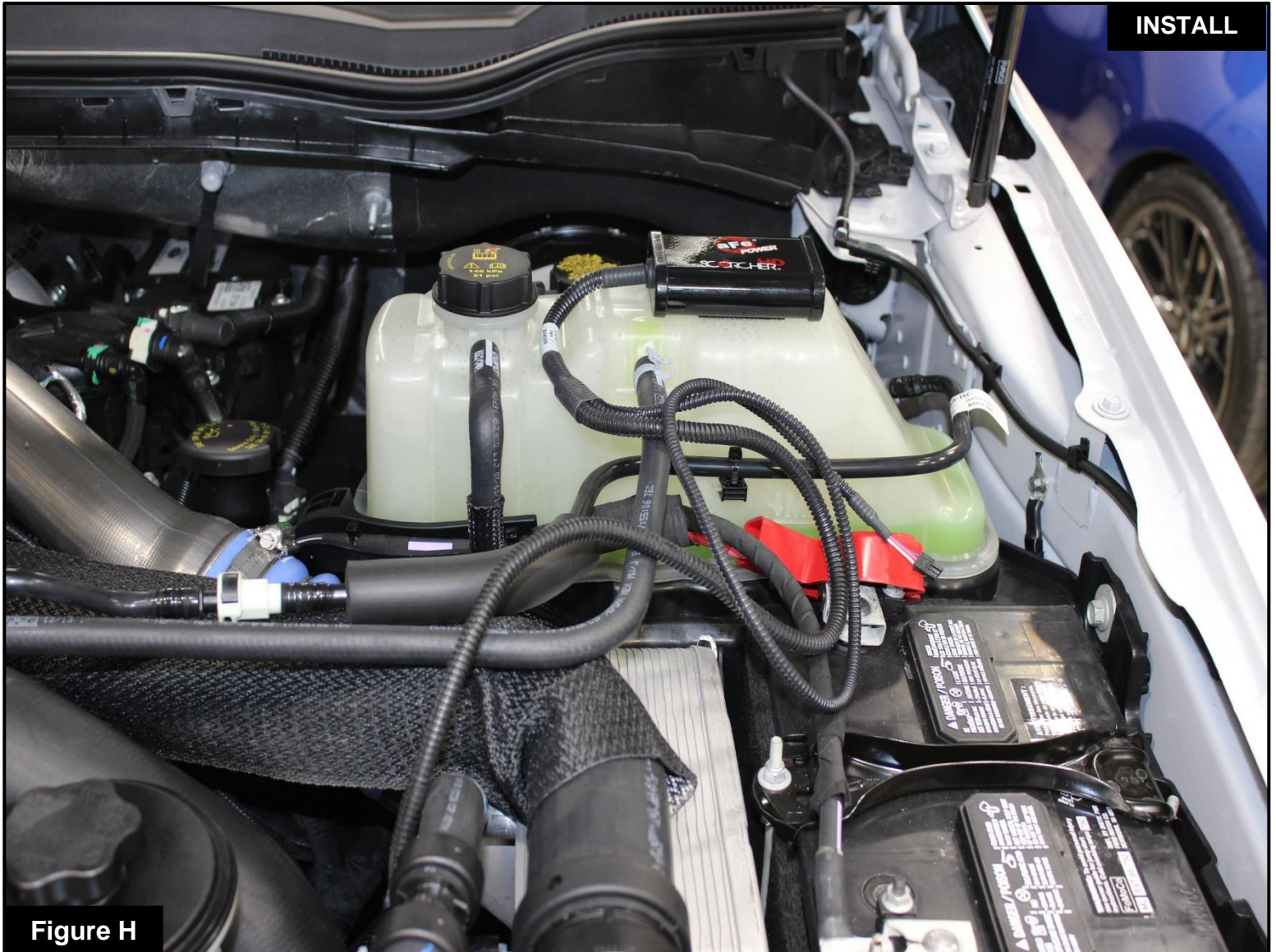

**Figure H****Refer to Figure H for Step 12**

Step 12: Secure the Scorcher module on top of the fuse box near the master cylinder, or any other desired location using the Velcro provided. The module must be located within reach of the LED switch harness.

**The door can now be opened to proceed with the installation of the LED switch.**





Figure I

**Refer to Figure I for Steps 13-14**

Step 13: Select the desired location for the LED switch. Route the cable on the back of the switch to exit towards the top or the bottom of the switch

Step 14: Use the provided double sided tape to secure the LED switch in the desired location.



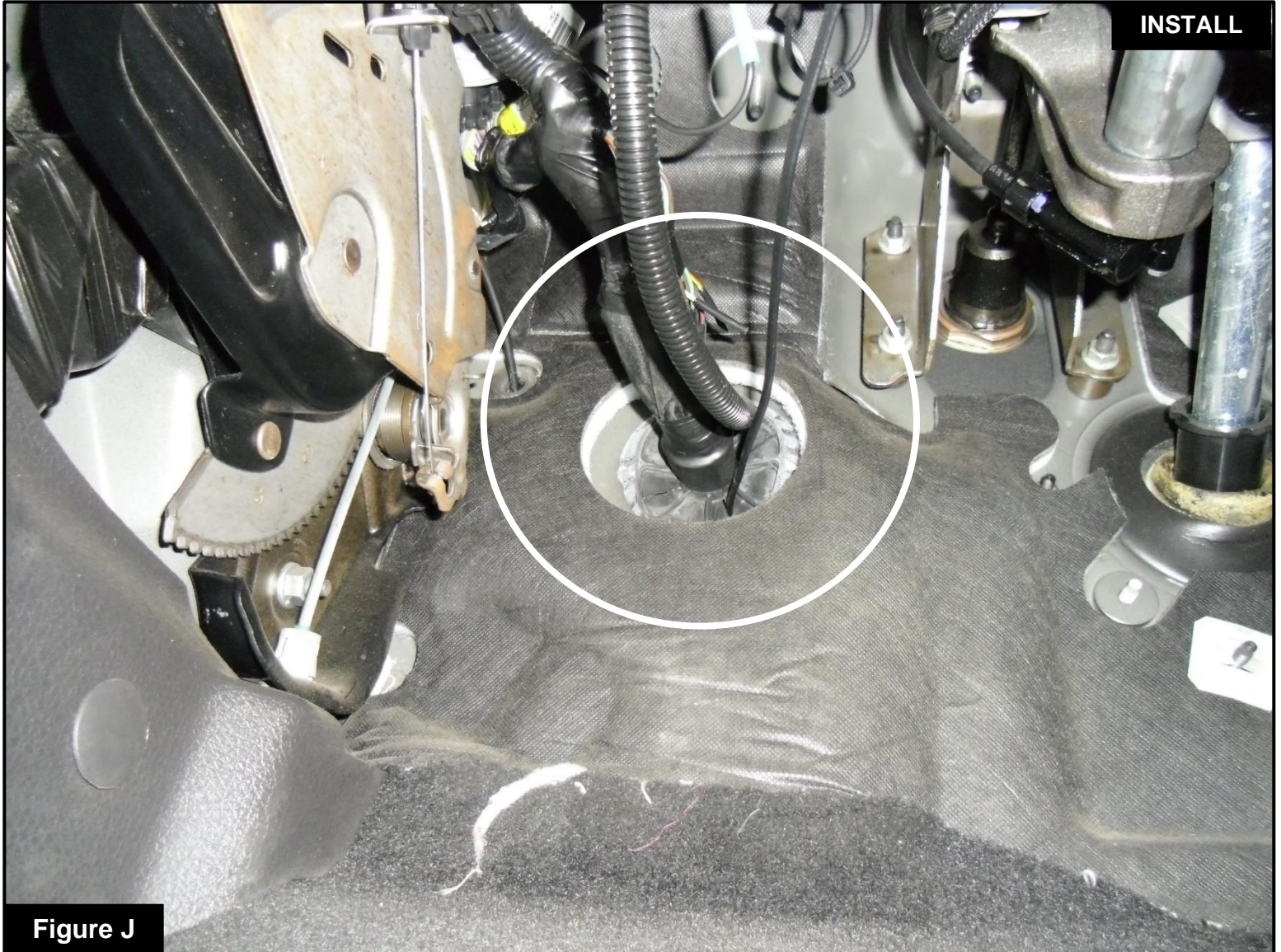

**Refer to Figure J for Steps 15-16**

Step 15: Carefully route the switch cable behind the steering wheel cover or cabin trim cover.

Step 16: Route the switch cable through the firewall and into the engine bay. Follow the main harness through the grommet into the firewall.

**Figure K**

### **Refer to Figure K for Steps 17-18**

Step 17: Plug the end of the switch cable to the aFe POWER harness inside the engine compartment.

Step 18: Secure all wires away from any extreme heat and moving parts with the provided zip ties. Make sure all connections are secured and fully engaged.

**The installation of the module itself is now complete. Keep reading the installation instructions to learn how to use all of its features.**





Figure L

### **Refer to Figure L (LED Switch)**

When turning on the vehicle, each LED will flash, and it will stop at its last setting. The LED on the switch represents the different level of power.

- Green LED: Stock
- Yellow LED: Sport
- Orange LED: Sport+
- Red LED: Race

Use the grey button to select the desired setting. Power adjustments can be done at any time while the unit is on. Thank you for choosing aFe POWER.



**Page left blank intentionally.**



**Page left blank intentionally.**





Mechanic Gloves



P/N: 40-10149

Power Bank: 10,000Mah



P/N: 40-10198

USB LED Flashlight



P/N: 40-10202

aFe POWER Diesel Frame

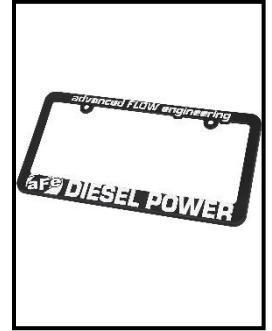

P/N: 40-10204

Power Stroke 6.7L Banner



P/N: 40-10215

aFE Diesel Tee-Shirt



P/N: 40-30221

aFe POWER Tactical Backpack



P/N: 40-33205-B

Black Beverage Cooler



P/N: 40-10121

To purchase any of the items above, view airflow charts, dyno graphs, photos, and video; please go to [aFepower.com](http://aFepower.com).



# Warranty

## General Terms:

- aFe warrants their products to be free from manufacturer's defects due to workmanship and material.
- This warranty applies only to the original purchaser of the product and is non-transferrable.
- Proof of purchase of the aFe product is required for all warranty claims.
- Warranty is valid provided aFe instructions for installation and/or cleaning were properly followed.
- Proper maintenance with regular inspections of product is required to insure warranty coverage.
- Damage due to improper installation, abuse, unauthorized repair or alteration is not warranted.
- Incidental or consequential damages or cost, including installation and removal of part, incurred due to failure of aFe product is not covered under this warranty.
- All warranty is limited to the repair and/or replacement of the aFe part. To request Return Goods Authorization ("RGA"), email RGA@afepower.com or call (951)493-7100. Upon receipt of the RGA, you must return the product to the address provided in the RGA, freight prepaid and accompanied with a dated proof of purchase and the RGA. Upon receipt of the defective product and upon verification of proof of purchase, aFe will either repair or replace the defective product within a reasonable time, not to exceed thirty days.

Product Category	P/N Prefix	Warranty duration
Direct OE Replacement Filters	10, 11, 30, 31, 71, 73	Life of the vehicle
Racing Filters	18	1 year
Universal	20, 21, 23, 24, 72, TF	2 years
Air Intake Systems	50, 51, 53, 54, 55, 56, 57, 58, 75, TR, TA, TL, TM	2 years
Exhaust Systems	49	2 years
Intercoolers & Intercooler Tubes	46-2	2 years
Intake Manifolds	46-1	2 years
Differential Cover	46-7	Life of the vehicle
Exhaust Manifolds	46	2 years
Throttle Body Spacers	46-3	2 years
Turbochargers	46-6	2 years*
Fluid Filters	44	90 days
Pre-Filters	28	2 years
Heavy Duty OE Replacement	70	2 years
PowerSports OE Replacement	81, 87	2 years
Tuners	77	1 year

No other warranty expressed or implied applies nor is any person or advanced FLOW engineering authorized to assume any other warranty. Some States do not allow the exclusion or limitation of incidental or consequential damages or do not allow limitations on how long an implied warranty lasts, so the above limitations or exclusions may not apply to you. This warranty gives you specific legal rights, and you may also have other rights which vary from State to State.

\*See turbocharger warranty for more info

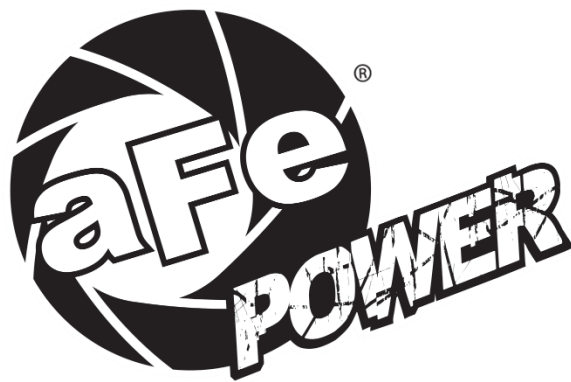

***advanced FLOW engineering, inc.***

252 Granite Street Corona, CA 92879  
TEL: 951.493.7100 • TECH: 951.493.7185  
E-Mail: Tech@aFepower.com

P/N: 06-81350

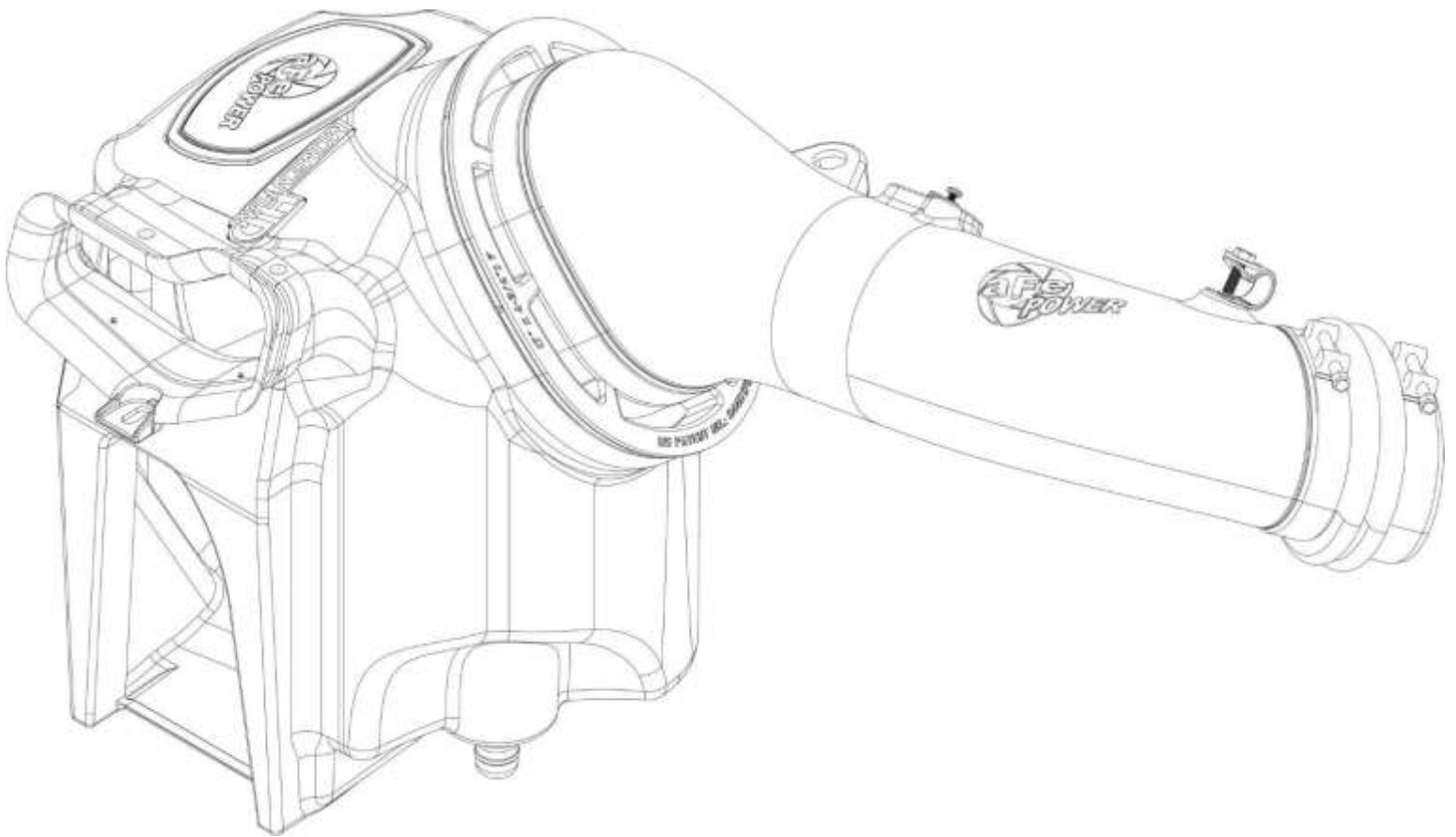

advanced FLOW engineering Momentum HD Cold Air Intake System

**Instruction Manual** P/N: 50-70007D / 50-70007T

Make: Ford

Model: Super Duty F-250/F350

Year: 2020-2021

Engine: V8-6.7L (td)





- Please read the entire instruction manual before proceeding.
- Ensure all components listed are present.
- For technical support please call 951-493-7185.
- Ensure you have all necessary tools before proceeding.
- Do not attempt to work on your vehicle when the engine is hot.
- Retain factory parts for future use.

Label	Qty.	Description	Part Number
A1	1	Air Filter (Pro 5R)	24-91061
A2	1	Air Filter (Pro DRY S)	21-91061
B	1	Tube	05-5070058B1
C	1	Housing	05-5070058B2
D	1	Coupling, Silicone Bellows	05-01430
E	2	Clamp, T-bolt (4-9/16" - 4-7/8")	03-50319
F	1	Seal, Trim	05-01553
G	1	Clamp, T-bolt (8-5/16" - 8-5/8")	03-50267
H	1	Plug, Silicone	05-01429
I	2	Screw, Torx: M4x10mm	03-50490
J	4	Retainer Clip	05-01554
K	1	Fixing Clamp, 3/4"ID	03-50234
L	1	Washer, Flat: M6	03-50070
M	1	Screw, Hex Hd: M6x1x20, Gr 8.8	03-50057

**Installation will require the following tools:**

Panel clip remover, T20 Torx driver, 7mm & 10mm nut drivers, 7mm socket, 10" extension, 11mm deep socket and driver

**Emissions Disclaimer:** This product is not currently CARB exempt and is not available for purchase in California or for use on any vehicle registered with the California Department of Motor Vehicles.

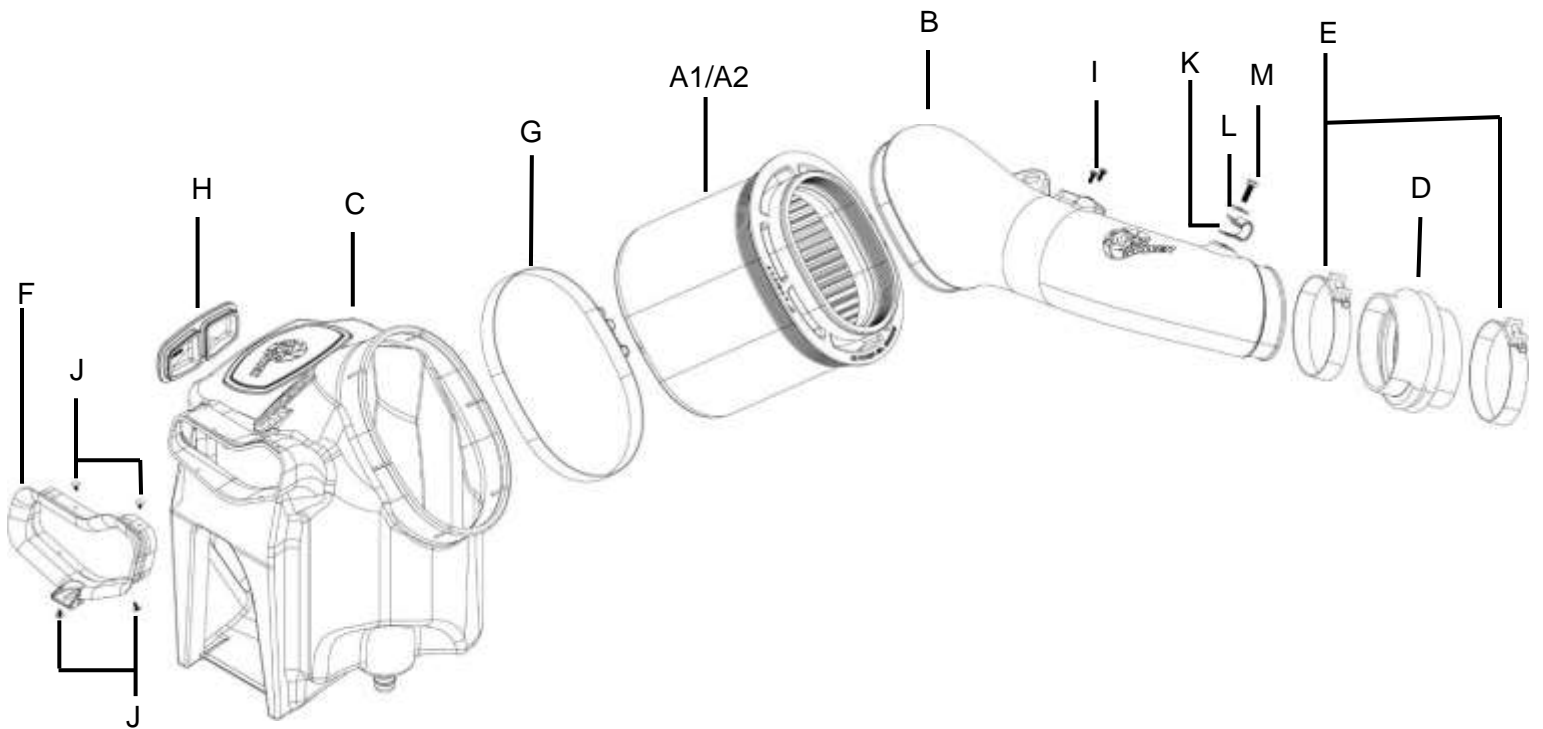

**Figure A****Refer to Figure A for Step 1**

Step 1: Using a 7mm nut driver, loosen the clamps ① at the turbo inlet and the air filter cover. Remove the hose ② from the intake tube clip and remove the intake tube ③.





**Figure B**

**Refer to Figure B for Steps 2-6**

- Step 2: Disconnect the MAF sensor (4) and the clip (5) holding the harness.
- Step 3: Unclip the three tabs (6) from the air filter cover.
- Step 4: Remove the air filter cover and air filter.
- Step 5: Using a panel clip remover, remove the retaining plastic clip (7) holding part of the scoop seal down and set aside for later use.
- Step 6: Snap out the plastic scoop (8) from the air filter housing.

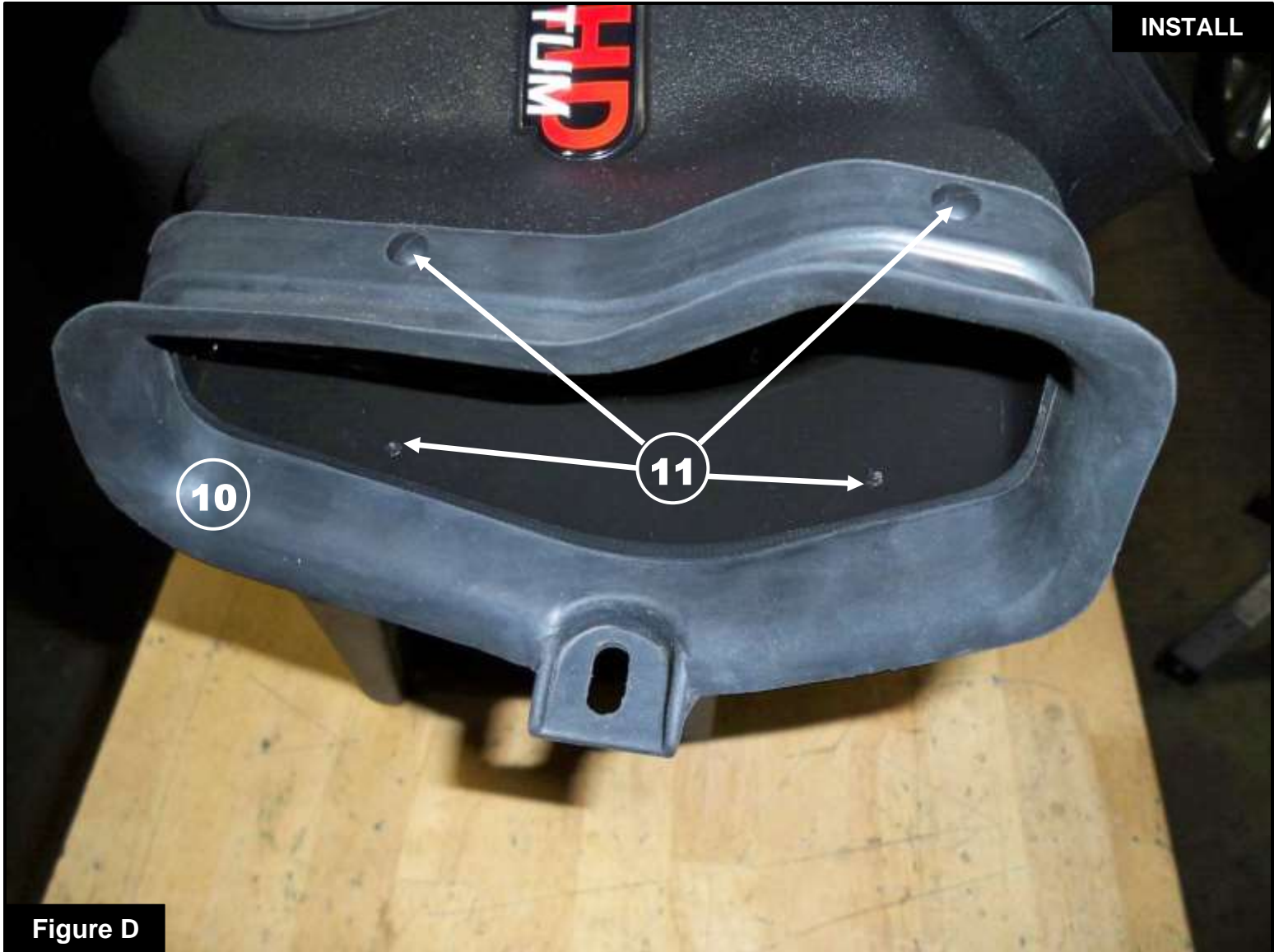

**Figure C**

**Refer to Figure C for Steps 7-8**

Step 7: Using a 7mm socket, extension & driver, remove the screw ⑨ holding the air filter housing to the grill inlet duct.

Step 8: Remove the air filter housing by pulling it straight up from its mounting grommets.

**Figure D****Refer to Figure D for Steps 9-10**

Step 9: Place the scoop seal trim ⑩ on the scoop opening of the aFe POWER housing.

Step 10: Align the holes from the scoop seal trim and the aFe POWER housing. Insert all four retainer clips ⑪ fully into the cavities and make sure the seal trim is secure to the aFe POWER housing.





Figure E

**Refer to Figure E for Step 11**

Step 11: Remove the two grommets (12) from the air filter housing and install them onto the aFe POWER housing. Make sure they are fully seated past the bead.



### **Refer to Figure F for Steps 12-13**

Step 12: Install the aFe POWER housing on to vehicle. Make sure the bottom mounting pin is fully seated in the mounting grommet and the two side mounting pins with grommets are fully engaged on the mounting bracket.

Step 13: Make sure the scoop seal trim seats behind the plastic trim cover (please see picture). Install the retaining plastic clip (13) removed on step 5 to secure the trim seal.





Figure G

**Refer to Figure G for Steps 14-16**

Step 14: Slide the large T-Bolt clamp (14) over the air filter opening on the aFe POWER housing.

Step 15: Slide the aFe POWER filter with clamp into the housing. Do not tighten the clamps.

Step 16: Use the provided plug (15) to close the additional air inlet if you want to completely seal the airbox.

Best performance gain is obtained by having more air flow (no plug).

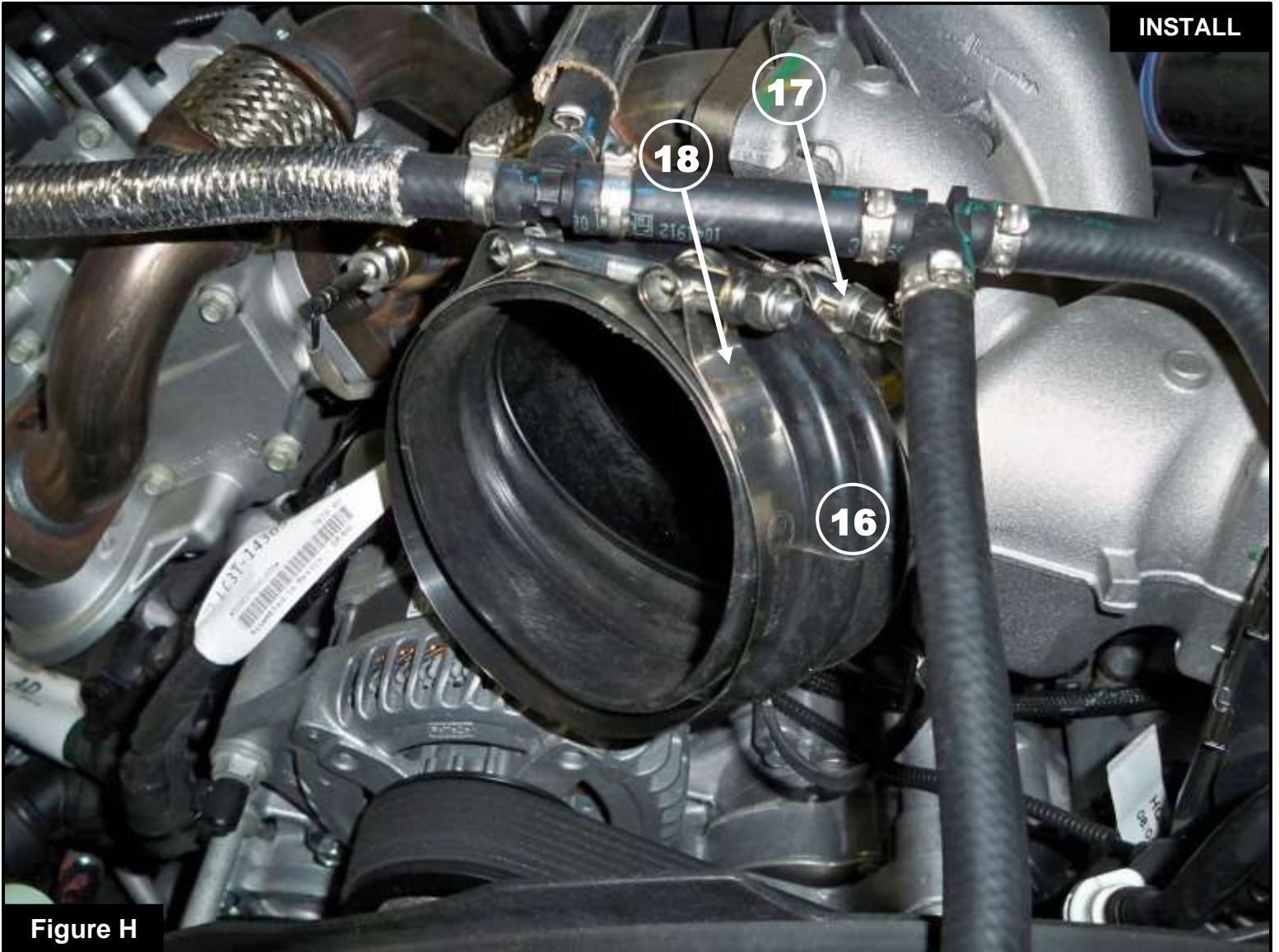

**Figure H****Refer to Figure H for Steps 17-18**

Step 17: Place the supplied aFe POWER coupling (16) and a TB487SS clamp (17) over the turbo inlet. Do not tighten.

Step 18: Place the other supplied TB487SS clamp (18) on the installed coupling. Do not tighten.



Figure I

**Refer to Figure I for Steps 19-20**

Step 19: Using a T20 Torx driver, remove the MAF sensor (19) from the air filter cover and install it on the aFe POWER intake tube using the supplied M4 screws.

Step 20: Remove the filter minder and grommet (20) from the air filter cover and install them onto the aFe intake tube.



**Figure J****Refer to Figure J for Steps 21-22**

Step 21: Install the aFe POWER intake tube into the vehicle. Slide the tube into the throttle body coupling first, then into the air filter.

Step 22: Align the coupler, intake tube and clamps correctly, then using a 11mm deep socket and driver tighten all the clamps (21).



**Figure K****Refer to Figure K for Steps 23-25**

Step 23: Secure the hose to the tube with the provided fixing clamp, 6mm screw and washer ②②. Using a 10mm nut driver, tighten the screw.

Step 24: Reconnect the MAF sensor ②③.

Step 25: Check all the components are tight and secure. Your installation is now complete. Thank you for choosing aFe POWER!

**NOTE: Check all bolts, clamps, and connectors after 100-200 miles.**



**Page left blank intentionally**



**Page left blank intentionally**





**Page left blank intentionally**



Pro DRY S Air Filter



P/N: 21-91061

Pro 10R Air Filter



P/N: 20-91061

Pro DRY S Restore Kit



P/N: 90-59999

Blue Squeeze Restore Kit



P/N: 90-50501

Pre-Filter



P/N: 28-10283

aFe Fender Cover



P/N: 40-10230

SCORCHER BLUE Module



P/N: 77-83042

SCORCHER HD Module



P/N: 77-43042

Pro GUARD D2 Oil Filter



P/N: 44-LF024

Rebel XD Exhaust System



P/N: 49-43102-B (Blk. Tips)  
49-43102-P (Pol. Tips)

ATLAS 5" Exhaust System



P/N: 49-03090-B (Blk. Tips)  
49-03090-P (Pol. Tips)

Large Bore-HD 5" Exhaust System



P/N: 49-43090-B (Blk. Tips)  
49-43090-P (Pol. Tips)

To purchase any of the items above, view airflow charts, dyno graphs, photos, and video; please go to [aFepower.com](http://aFepower.com).



# Warranty

## General Terms:

- aFe warrants their products to be free from manufacturer's defects due to workmanship and material.
- This warranty applies only to the original purchaser of the product and is non-transferrable.
- Proof of purchase of the aFe product is required for all warranty claims.
- Warranty is valid provided aFe instructions for installation and/or cleaning were properly followed.
- Proper maintenance with regular inspections of product is required to insure warranty coverage.
- Damage due to improper installation, abuse, unauthorized repair or alteration is not warranted.
- Incidental or consequential damages or cost, including installation and removal of part, incurred due to failure of aFe product is not covered under this warranty.
- All warranty is limited to the repair and/or replacement of the aFe part. To request Return Goods Authorization ("RGA"), email RGA@afepower.com or call (951)493-7100. Upon receipt of the RGA, you must return the product to the address provided in the RGA, freight prepaid and accompanied with a dated proof of purchase and the RGA. Upon receipt of the defective product and upon verification of proof of purchase, aFe will either repair or replace the defective product within a reasonable time, not to exceed thirty days.

Product Category	P/N Prefix	Warranty duration
Direct OE Replacement Filters	10, 11, 30, 31, 71, 73	Life of the vehicle
Racing Filters	18	1 year
Universal	20, 21, 23, 24, 72, TF	2 years
Air Intake Systems	50, 51, 53, 54, 55, 56, 57, 58, 75, TR, TA, TL, TM	2 years
Exhaust Systems	49	2 years
Intercoolers & Intercooler Tubes	46-2	2 years
Intake Manifolds	46-1	2 years
Differential Cover	46-7	Life of the vehicle
Exhaust Manifolds	46	2 years
Throttle Body Spacers	46-3	2 years
Turbochargers	46-6	2 years*
Fluid Filters	44	90 days
Pre-Filters	28	2 years
Heavy Duty OE Replacement	70	2 years
PowerSports OE Replacement	81, 87	2 years
PowerSports Intake Systems	85	2 years

No other warranty expressed or implied applies nor is any person or advanced FLOW engineering authorized to assume any other warranty. Some States do not allow the exclusion or limitation of incidental or consequential damages or do not allow limitations on how long an implied warranty lasts, so the above limitations or exclusions may not apply to you. This warranty gives you specific legal rights, and you may also have other rights which vary from State to State.

\*See turbocharger warranty for more info





advanced FLOW engineering, inc.

252 Granite Street Corona, CA 92879  
TEL: 951.493.7100 • TECH: 951.493.7134  
E-Mail: Tech@aFepower.com

P/N: 06-81344