

INSTALLATION INSTRUCTIONS

69-8757TTK

TOYOTA

2009-16 Corolla

L4-1.8L

NOTE: EXCLUDES ECO MODELS

TOOLS NEEDED:

phillips screwdriver
3mm allen wrench
10mm socket
12mm socket
10mm wrench
extension
ratchet

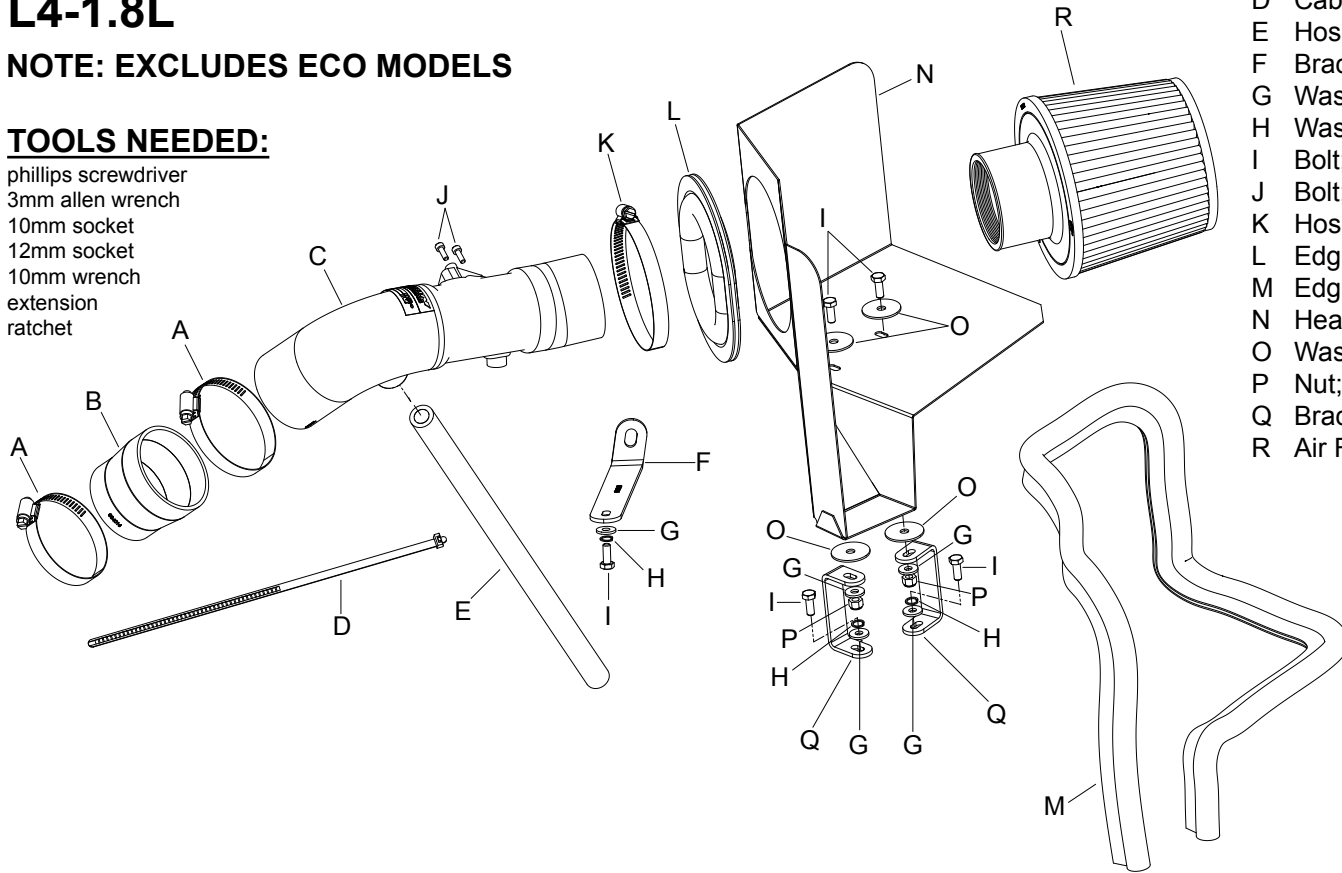

PARTS LIST:

Description	Qty.	Part #
A Hose Clamp #40	2	08554
B Hose; 2-1/2" To 2-3/4" Tprd., Blk.	1	084016
C Intake Tube	1	27555-1TTK
D Cable Tie; 11" Blk.	1	21590
E Hose; 5/8"ID X 20"L, Blk. Silicone	1	08542
F Bracket; "L", Stl., FB/PC	1	070110
G Washer; 1/4"ID X 5/8"OD - SAE	5	08275
H Washer; 1/4" Lock, ZN	3	08198
I Bolt; 6MM-1.00 X 16MM, SS	5	07812
J Bolt; M4 - 0.07 8MM, A/H Cap., SS	2	07733
K Hose Clamp #44	1	08577
L Edge Trim (17")	1	102469
M Edge Trim (56")	1	102490
N Heat Shield	1	074048
O Washer; 1.25D X. 28 HOL ZN	4	08151
P Nut; 6MM Nylock, Hex Head, SS	2	07512
Q Bracket; "C", Stl., FB/PC	2	070052
R Air Filter	1	RU-4960XD

NOTE: FAILURE TO FOLLOW INSTALLATION INSTRUCTIONS AND NOT USING THE PROVIDED HARDWARE MAY DAMAGE THE INTAKE TUBE, THROTTLE BODY AND ENGINE.

TO START:

1. Turn off the ignition and disconnect the negative battery cable.

NOTE: Disconnecting the negative battery cable erases pre-programmed electronic memories. Write down all memory settings before disconnecting the negative battery cable. Some radios will require an anti-theft code to be entered after the battery is reconnected. The anti-theft code is typically supplied with your owner's manual. In the event your vehicles' anti-theft code cannot be recovered, contact an authorized dealership to obtain your vehicles anti-theft code.



2. Pull up firmly to dislodge the engine cover from the mounting grommets and then remove the cover from the engine.



3. Disconnect the crank case vent hose from the valve cover port as shown.



4. Disconnect the mass air sensor electrical connection. Then unhook the mass air sensor wiring harness from the upper air box.



5. Loosen the hose clamp which secures the intake tube to the throttle body.



6. Unclip the upper air box retaining clips and then remove the upper air box and intake assembly.



7. Remove the three lower air box retaining bolts. Then unclip the wiring harness from the rear of the air box and remove the lower air box housing from the vehicle.

NOTE: K&N Engineering, Inc., recommends that customers do not discard factory air intake.



8. Remove the bolt shown which secures the engine wiring harness to the engine.

NOTE: This bolt will be reused.



9. Install the two heat shield mounting brackets (070052) onto the air box mounting bracket as shown.

NOTE: Be sure to install the brackets 180° or in the opposite direction from each other.

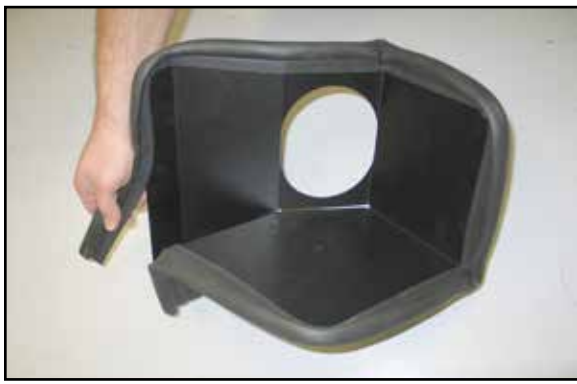

10. Install the provided long edge trim onto the heat shield as shown.

NOTE: Some trimming of the edge trim will be necessary.



11. Install the provided short edge trim into the heat shield as shown.

NOTE: Some trimming of the edge trim will be necessary.



12. Install the heat shield assembly onto the mounting brackets installed in step #9 using the provided hardware.



13. Install the provided silicone hose (084016) onto the throttle body and secure with the provided hose clamp.



14. Remove the two screws that secure the mass air sensor to the upper air box and then remove the mass air sensor as shown.



15. Install the mass air sensor into the K&N® intake tube and secure with the provided hardware.



16. Install the tube mounting bracket (070110) onto the engine using the bolt removed during step #8.



17. Install the K&N® intake tube into the silicone hose at the throttle body and align with the bracket installed in the previous step. Secure the intake tube with the provided hose clamp and hardware.



18. Install the crank case vent hose onto the valve cover port and then onto the K&N® intake tube.

NOTE: Be sure to route the vent hose so that it is not kinked and then secure with the provided tie wrap. Some trimming of the vent hose may be necessary.



19. Route the mass air electrical harness through the heat shield as shown and then reconnect the mass air sensor electrical connection.



20. Install the K&N® air filter onto the intake tube and secure with the provided hose clamp.
NOTE: Drycharger® air filter wrap; part # RX-4990DK is available to purchase separately. To learn more about Drycharger® filter wraps or look up color availability please visit <http://www.knfilters.com>®.



21. Reconnect the vehicle's negative battery cable. Double check to make sure everything is tight and properly positioned before starting the vehicle.

22. It will be necessary for all K&N® high flow intake systems to be checked periodically for realignment, clearance and tightening of all connections. Failure to follow the above instructions or proper maintenance may void warranty.

ROAD TESTING:

1. Start the engine with the transmission in neutral or park, and the parking brake engaged. Listen for air leaks or odd noises. For air leaks secure hoses and connections. For odd noises, find cause and repair before proceeding. This kit will function identically to the factory system except for being louder and much more responsive.

2. Test drive the vehicle. Listen for odd noises or rattles and fix as necessary.

3. If road test is fine, you can now enjoy the added power and performance from your kit.

4. K&N Engineering, Inc., requires cleaning the intake system's air filter element every 100,000 miles. When used in dusty or off-road environments, our filters will require cleaning more often. We recommend that you visually inspect your filter once every 25,000 miles to determine if the screen is still visible. When the screen is no longer visible some place on the filter element, it is time to clean it. To clean and re-oil, purchase our filter Recharger® service kit, part number 99-5050 or 99-5000 and follow the easy instructions.

LEGAL IN CALIFORNIA ONLY FOR RACING VEHICLES WHICH MAY NEVER BE USED, REGISTERED OR LICENSED FOR USE UPON A HIGHWAY.

See knfilters.com for CARB status on each part for a specific vehicle