

## INSTALLATION INSTRUCTIONS

### 69-4529TS CHEVROLET 2013-16 Malibu L4-2.5L

#### TOOLS NEEDED:

ratchet  
extension  
15mm socket  
10mm socket  
flat blade screw driver  
pliers  
side cutters  
t27 torx  
t20 torx

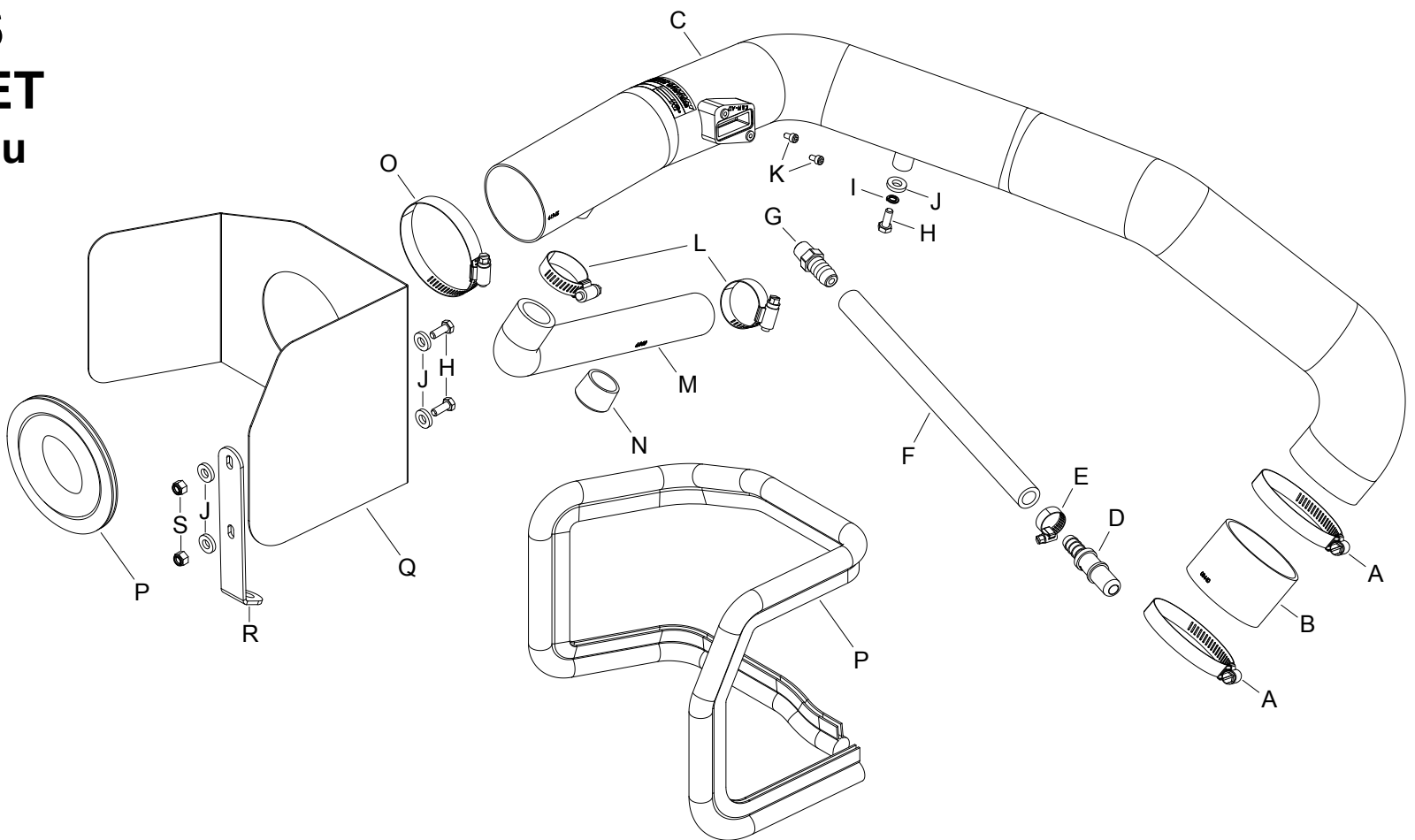
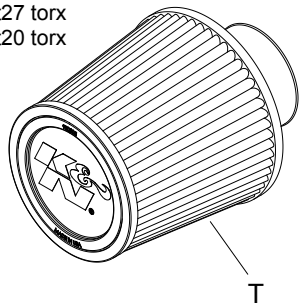

#### PARTS LIST:

Description	Qty.	Part #	Description	Qty.	Part #	Description	Qty.	Part #
A Hose Clamp #44 Stainless	2	08560	H Bolt; 6MM-1.00 X 16MM ,SS	3	07812	O Hose Clamp #44	1	08577
B Hose; 2-3/4" ID X 2"L Reinforced	1	08440	I Washer; M6 Split Lock Zinc	1	1-3025	P Edge Trim (61")	1	102492
C Intake Tube	1	27619TS	J Washer; 1/4"ID X 5/8"OD- SAE	5	08275	Q Heat Shield	1	073170
D Vent; 1/2"Barb To quick	1	82629	K Bolt; M4-0.07 8MM, A/H Cap, SS	2	07733	R Bracket; "L", 69-4529, STL	1	064322
E Hose Clamp #6 Mini	1	08407	L Hose Clamp #16	2	08413	S Nut; 6MM Nylock, Hexhead, SS	2	07512
F Hose; 1/2" ID X 9"L	1	08401	M Hose; 1" ID X 11"L W/1" L 90	1	08479	T Air Filter	1	RU-4960
G Vent; 1/2" Hose, 1/4"	1	080022	N Caplug; 15/16" ID, 3/4"L, BLK	1	08246			

If you need any assistance please call 1-800-858-3333 to speak with a representative in our Customer Service Center before returning the product.

**NOTE: FAILURE TO FOLLOW INSTALLATION INSTRUCTIONS AND NOT USING THE PROVIDED HARDWARE MAY DAMAGE THE INTAKE TUBE, THROTTLE BODY AND ENGINE.**

#### TO START:

1. Turn off the ignition and disconnect the negative battery cable.

**NOTE: Disconnecting the negative battery cable erases pre-programmed electronic memories. Write down all memory settings before disconnecting the negative battery cable. Some radios will require an anti-theft code to be entered after the battery is reconnected. The anti-theft code is typically supplied with your owner's manual. In the event your vehicles anti-theft code cannot be recovered, contact an authorized dealership to obtain your vehicles anti-theft code.**



2. Disconnect the mass air sensor electrical connection.



3. On vehicles equipped with air injection, disconnect the air injection hose from the air box.



4. Loosen the hose clamp securing the intake tube to the air filter housing.



5. Lift up the rear of the air box so that it becomes disengaged with the mounting grommet saddle, and then remove the complete air box from the vehicle.

**NOTE: K&N Engineering, Inc., recommends that customers do not discard factory air intake.**



6. Remove the three screws securing the engine cover, remove the oil cap and then remove the engine cover. Reinstall the oil cap for now to prevent debris from entering the engine.





7. Remove the bolt shown securing the intake plenum to the engine.



8. Loosen the hose clamp securing the intake tube to the throttle body.



9. As the intake plenum is being lifted off, release the locking tabs on the two crank case vents and disconnect the crank case vents from the valve cover. Once the intake plenum is free, remove it from the vehicle.



10. Remove the crank case hose assembly from the intake plenum.

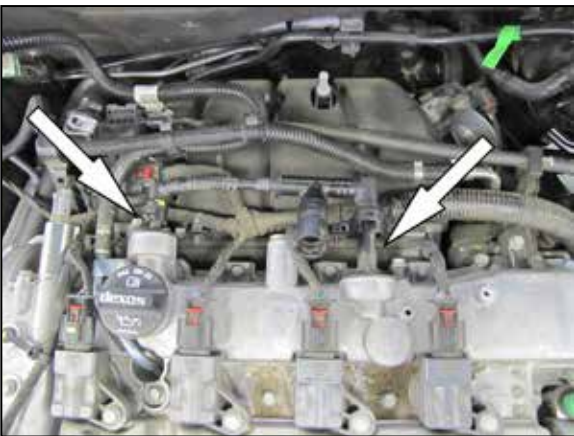

11. Reinstall the crank case vent assembly onto the valve cover.



12. On vehicles equipped with air injection, cut the clamp at the air injection hose union and then separate the air injection hose and remove the loose section from the vehicle.



13. On vehicles equipped with air injection, install the provided air injection hose (08479) onto the factory union and secure with provided hose clamp. **NOTE: Do not completely tighten at this time.**



14. Install the provided coupling hose (08440) onto the throttle body and secure with provided hose clamp.



15. Remove the two screws securing the mass air sensor and then remove the mass air sensor from the air box.



16. Install the mass air sensor into the K&N intake tube as shown.



17. On vehicles that are not equipped with air injection, install the provided cap plug onto the air injection port and secure with the provided hose clamp.



18. Install the provided npt vent fitting into the K&N intake tube as shown. **NOTE: Plastic NPT fittings are easy to cross thread. Install the vent fitting "hand" tight, then turn it two complete turns with a wrench.**



19. Remove the clip nut from the plenum mounting bracket.



20. Assemble the provided hose and quick connect fitting with the provided clamp.



21. Install the K&N intake tube into the coupler on the throttle body and align with the plenum mounting bracket. Secure the intake tube with the provided hardware and hose clamp. Install the provided crank case vent hose onto the fitting installed onto the K&N intake tube, then attach the hose to the factory crank case vent assembly and connect it to the factory fittings on the valve cover. **NOTE: Some trimming of the provided hose may be necessary to prevent the hose from pinching.**





22. On vehicles equipped with air injection, connect the hose to the fitting in the intake tube and secure with the provided hose clamp.



23. Install the provided heat shield mounting bracket (064322) onto the heat shield as shown and secure with the provided hardware.

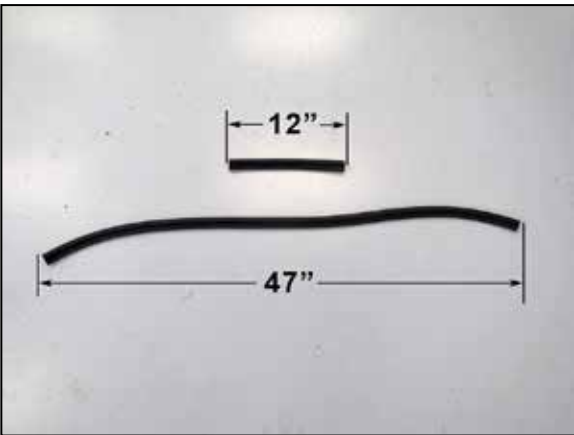

24. Cut the provided edge trim into two sections, one section should be 12" long. The longer section should be 47" long.



25. Install the shorter section into the hole of the heat shield and install the longer section around the perimeter of the heat shield as shown.



26. Remove the front engine mounting bolt shown.



27. Set the heat shield onto the engine mount so the bracket lines up with the engine mounting bolt hole. Reinstall the engine mounting bolt.



28. Install the K&N® air filter and secure with the provided hose clamp.  
**NOTE: Drycharger® air filter wrap; part # RX-4990DK is available to purchase separately. To learn more about Drycharger® filter wraps or look up color availability please visit <http://www.knfilters.com>®.**



29. Reconnect the mass air sensor electrical connection.



30. Reinstall the engine cover and secure with the factory bolts.



31. Reconnect the vehicle's negative battery cable. Double check to make sure everything is tight and properly positioned before starting the vehicle.

32. It will be necessary for all K&N® high flow intake systems to be checked periodically for realignment, clearance and tightening of all connections. Failure to follow the above instructions or proper maintenance may void warranty.

#### ROAD TESTING:

1. Start the engine with the transmission in neutral or park, and the parking brake engaged. Listen for air leaks or odd noises. For air leaks secure hoses and connections. For odd noises, find cause and repair before proceeding. This kit will function identically to the factory system except for being louder and much more responsive.
2. Test drive the vehicle. Listen for odd noises or rattles and fix as necessary.
3. If road test is fine, you can now enjoy the added power and performance from your kit.
4. K&N Engineering, Inc., requires cleaning the intake system's air filter element every 100,000 miles. When used in dusty or off-road environments, our filters will require cleaning more often. We recommend that you visually inspect your filter once every 25,000 miles to determine if the screen is still visible. When the screen is no longer visible some place on the filter element, it is time to clean it. To clean and re-oil, purchase our filter Recharger® service kit, part number 99-5050 or 99-5000 and follow the easy instructions.

**LEGAL IN CALIFORNIA ONLY FOR RACING VEHICLES WHICH MAY NEVER BE USED, REGISTERED OR LICENSED FOR USE UPON A HIGHWAY.**

See [knfilters.com](http://knfilters.com) for CARB status on each part for a specific vehicle