

MOMENTUM^{HD}

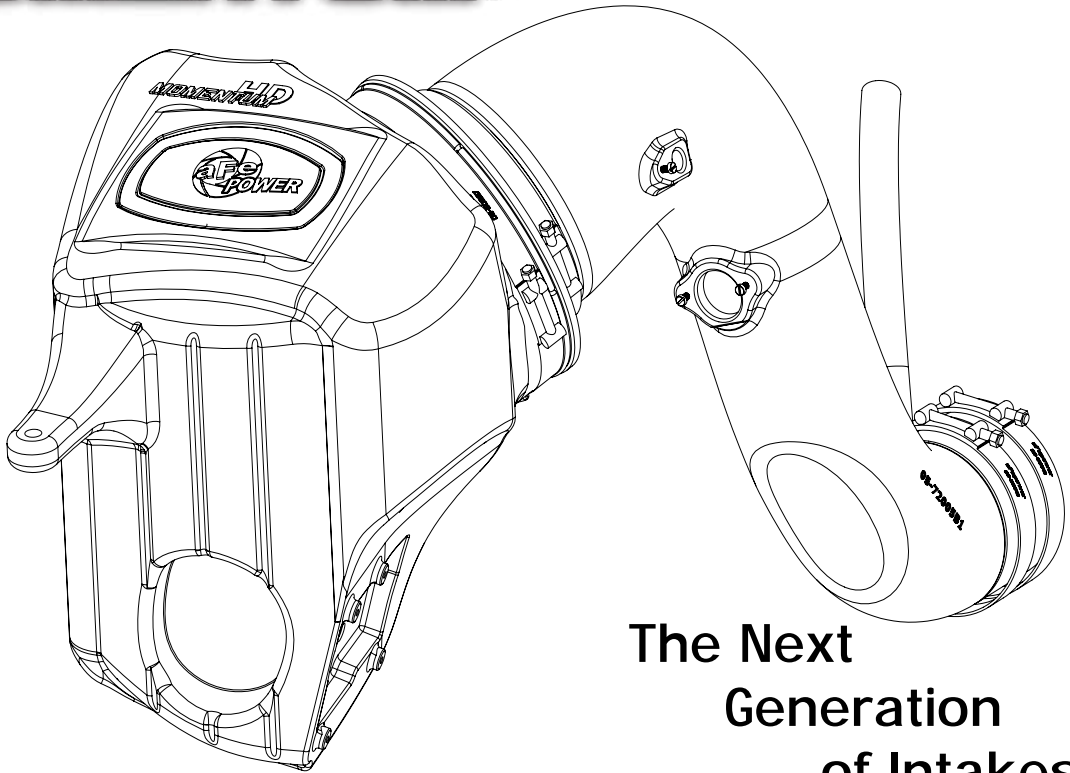

The Next
Generation
of Intakes

advanced FLOW engineering Momentum Air Intake

Instruction Manual P/N: 50-72005 / 51-72005 / 75-72005

Make: **RAM** Model: **Heavy Duty 2500** Year: **2013-2018** Engine: **L6-6.7L (td) Cummins**
Make: **RAM** Model: **Heavy Duty 3500** Year: **2013-2018** Engine: **L6-6.7L (td) Cummins**
Make: **RAM** Model: **Heavy Duty 4500** Year: **2013-2018** Engine: **L6-6.7L (td) Cummins**
Make: **RAM** Model: **Heavy Duty 5500** Year: **2013-2018** Engine: **L6-6.7L (td) Cummins**



- Please read the entire instruction manual before proceeding.
- Ensure all components listed are present.
- If you are missing any of the components, call technical support at 951-493-7100 or e-mail tech@afepower.com.
- Ensure you have all necessary tools before proceeding.
- Do not attempt to work on your vehicle when the engine is hot.
- Disconnect both the negative battery terminal before proceeding.

Retain factory parts for future use.

Label	Qty.	Description	Part Number
A1	1	Air Filter (Pro 10R)	20-91059
A2	1	Air Filter (Pro DRY S)	21-91059
A3	1	Air Filter (Pro-GUARD 7)	72-91059
B	1	Clamp- Mini (11/16"- 1-1/4")	03-50023
C	3	Screw, M4	03-50490
D	2	Clamp, T-Bolt (4-1/8" - 4-1/2")	03-50499
E	1	Clamp, T-Bolt (8-5/16" - 8-5/8")	03-50267
F	1	Hose 3/4" ID, Black (8")	05-00070
G	1	Coupling, Straight 4" ID	05-00715
H	1	Tube	05-72005B1
I	1	Housing	05-72005B2

Installation will require the following tools:

7mm, 8mm, 10mm and 13mm socket or nut driver, 1/2" socket, ratchet and extension, pliers, flat-head screwdriver, T30 torx driver.

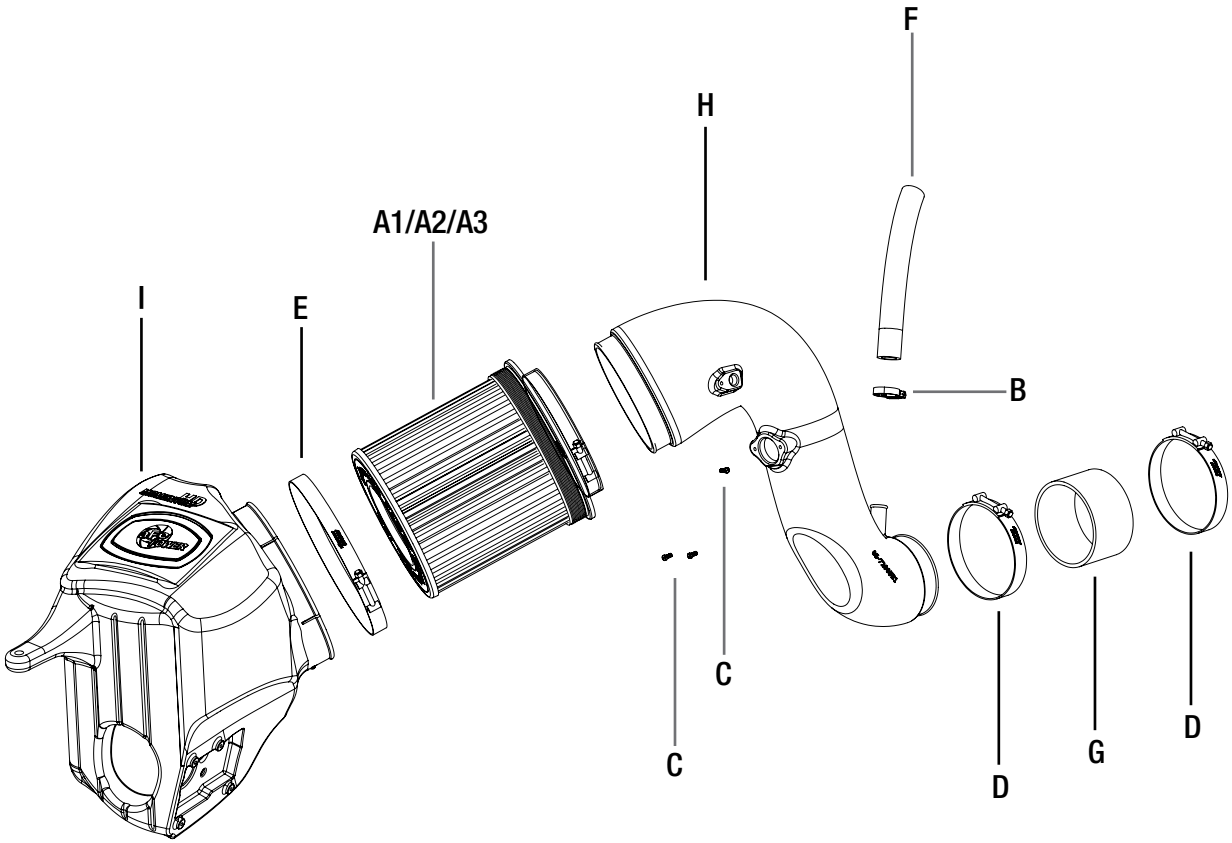

**Figure A****Refer to Figure A for steps 1-3**

Step 1: Disconnect the negative cable (1) on both batteries.

Step 2: Remove the screw holding (2) the factory air box down with a 1/2" socket.

Step 3: Disconnect the wiring harness from the Mass Air Flow (MAF) sensor (3) and temperature sensor (4).



Figure B

Refer to Figure B for steps 4-5

Step 4: Disconnect the crank case vent line (5) using pliers (factory clamp will be re-used).

Step 5: Loosen the clamp (6) connecting the factory intake tube to the turbocharger.

**Figure C****Refer to Figure C for step 6**

Step 6: Lift the entire factory intake system up out of the vehicle. Once you are able to reach it, disconnect the wiring harness ⑦ from the Ram Active Air Mechanism. Then pull the factory intake system out of the vehicle.

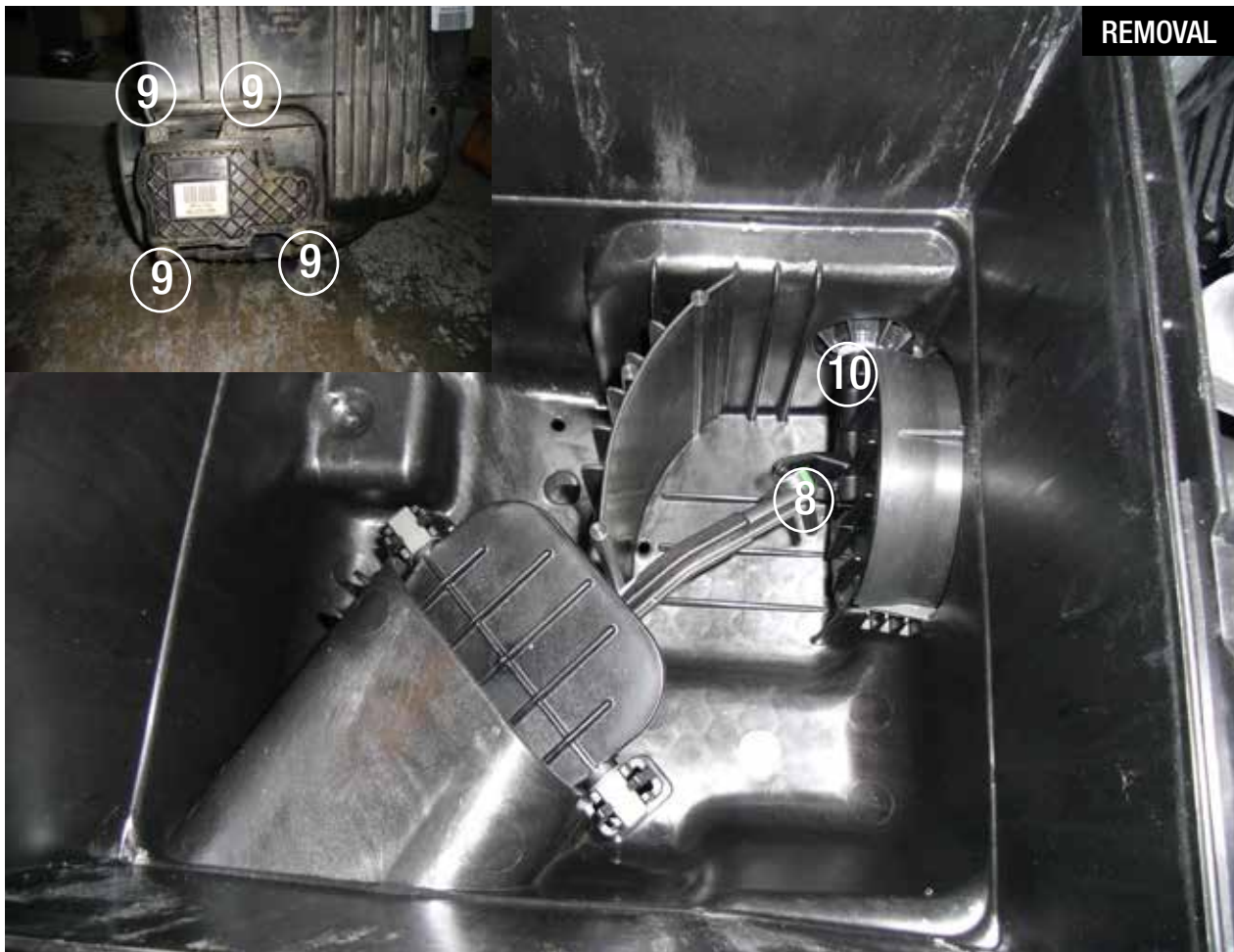
**Figure D****Refer to Figure D for steps 7-10**

Step 7: Open up the factory air box and remove the filter.

Step 8: Disconnect the ball (8) joint connected to the flap.

Step 9: Using a T30 torx driver, remove the screws (9) securing the Ram Active Air mechanism. Those screws will be re-used to install the Ram Active Air mechanism onto the aFe air box.

Step 10: Remove the flap (10) from the motor shaft. This will require a lot of force. Take the Ram Active Air motor and flap off the factory air box.

**Figure E****Refer to Figure E for steps 11-13**

- Step 11: Transfer the Ram Active Air motor to the aFe air box. Re-install the flap on the motor shaft by firmly pushing on it.
- Step 12: Secure the assembly to the aFe air box using the factory screws. Make sure the flap is fully engaged to the motor shaft.
- Step 13: Slide the aFe filter into the aFe housing. Install the larger clamps on the housing and filter. Do not tighten at this time.



Figure F

Refer to Figure F for steps 14-15

Step 14: Install the housing assembly into the vehicle. Re-connect the wiring harness to the Ram Active Air mechanism. Firmly push the housing into the factory mounting grommets.

Step 15: Re-install the factory screw (11) removed in step 2 to secure the housing. Do not completely tighten yet.

**Figure G****Refer to Figure G for steps 16-18**

- Step 16: Transfer the MAF sensor and the temperature sensor from the factory air box to the aFe tube. Use the furnished M4 screws to secure the sensors.
- Step 17: Install the supplied hose on the tube. Install supplied mini clamp on aFe tube side and tighten. Slide the factory clamp on the other end of the hose.
- Step 18: Install the furnished coupling and T-bolt clamps on the small end of the tube. Do not tighten yet.

**Figure H****Refer to Figure H for steps 19-20**

Step 19: Install the aFe tube into the vehicle by sliding the coupling over the turbo then by connecting the tube to the filter. Align the tube, filter and housing, then tighten all clamps and screws.

Step 20: Reconnect the hose (12) to the factory crankcase line. Using pliers, secure it with the factory clamp.



Figure I

Refer to Figure I for steps 21-23

Step 21: Reconnect the MAF sensor and temperature sensor harness.

Step 22: Reconnect both batteries.

Step 23: Verify all connections are secured. Your installation is now completed.

NOTE: Verify all connections are secured after 100-200 miles. Place enclosed CARB EO sticker on or near the intake system on a smooth/clean surface. EO identification label is required to pass the smog test inspection.

Page left blank intentionally



Air Filter



P/N: 20-91059 (P10R)
P/N: 21-91059 (PDS)
P/N: 72-91059 (PG7)

Pre-Filter



P/N: 28-10273

Pro DRY S Restore Kit



P/N: 90-59999

Blue Squeeze Restore Kit



P/N: 90-50501

Gold Squeeze Restore Kit



P/N: 90-50500

SCORCHER PRO Tune



P/N: 77-32001

SCORCHER BLUE Tune



P/N: 77-82009

SCORCHER HD Module



P/N: 77-42009

Turbo-Back Exhaust



P/N: 49-02047

Race Pipe Exhaust

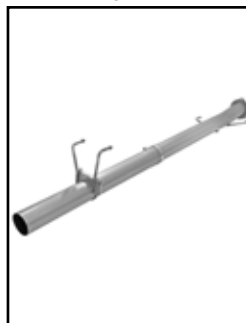

P/N: 49-42055

DFS780 Fuel System



P/N: 42-12036

Intercooler w/ Tubes



P/N: 46-20132-B

To purchase any of the items above, view airflow charts, dyno graphs, photos, and video; please go to aFepower.com.

Warranty

**For warranty information go to:
afepower.com/contact#warranty**

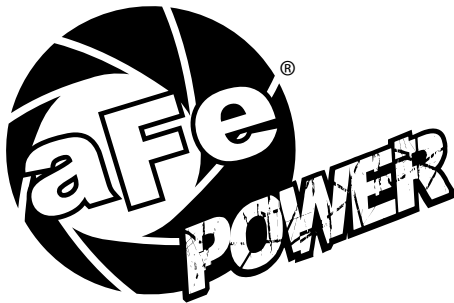

advanced FLOW engineering, inc.
252 Granite Street Corona, CA 92879
TEL: 951.493.7155 • TECH: 951.493.7134
E-Mail: Tech@aFepower.com