

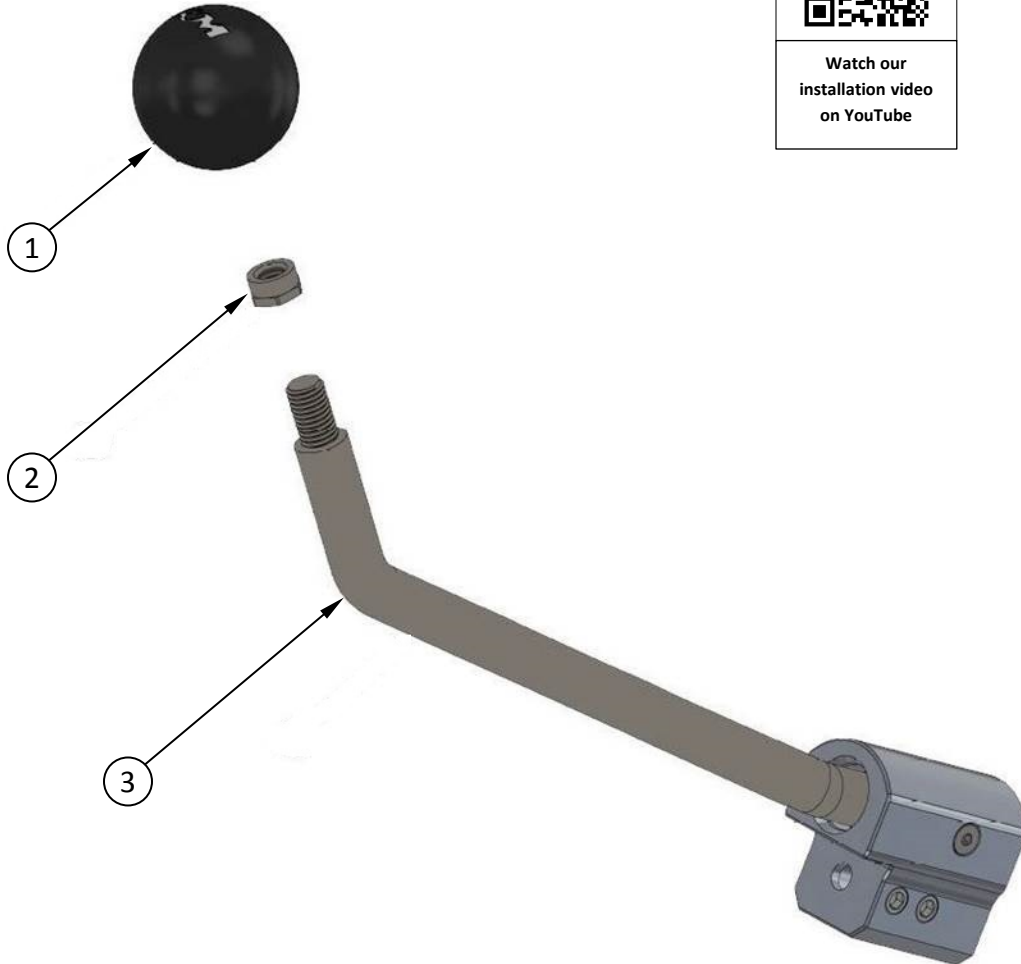

Watch our  
installation video  
on YouTube



ITEM NO.	PART NO.	DESCRIPTION	QTY.
1	4101359-88	SHIFT KNOB, JEEP WRANGLER JK	1
2	1794719	LOCK NUT, 3/8-16 UNC	1
3	N/A - SHIPS ASSEMBLED	SHIFT STICK AND ADAPTER ASSEMBLY, JEEP WRANGLER JK	1
N/A	4101348-88	• SHIFT STICK, JEEP WRANGLER JK	1
	4101349-88	• SHIFT STICK ADAPTER, JEEP WRANGLER JK	1
	3401546-00	• SET SCREW, 3/8-16 x 3/8, KNURL GRIP, CUP POINT	2
	8700124-00	• O-RING, 309 N70	4
	2156031	• SHOULDER BOLT, 1/4" DIA x 1/4" LONG x 10-32	2
	2596031	• ISOLATION SLEEVE, 1/4" ID x 1/4" LONG, BLUE VINYL	2

**Before starting**, take a moment to read and understand these instructions for your B&M Manual Shift Stick and Knob. Use the parts drawing and list (front page) to verify your kit's contents. In the unlikely event of missing parts, please contact B&M Technical Support for replacements.

**We highly recommend that you retain all factory parts.**

1. **Turn off your vehicle's ignition, set the parking brake, and shift both the transmission and the transfer case into NEUTRAL.**

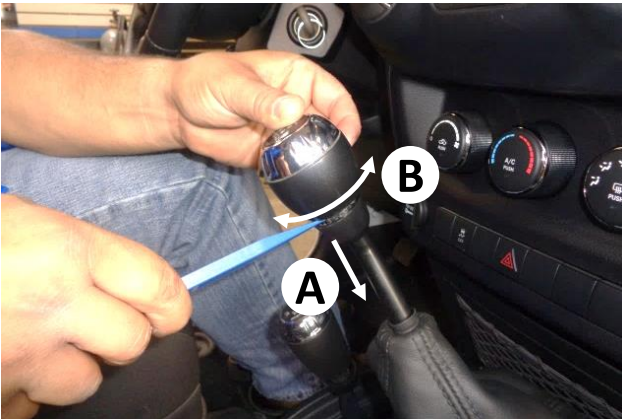

2. Use a trim tool to separate the trim ring from the bottom of the gearshift knob (A). Remove the knob by grasping it firmly with both hands and rotating it back and forth slightly (B) while sharply pulling it straight up. Finally, remove the trim ring from the shift lever. Repeat to remove the shift knob and trim ring from the transfer case.



3. Carefully lift the center console cover straight up to disengage it from the console, then remove the cover.



4. **CAUTION:** The sheet metal nut plate has sharp edges! Carefully remove the sheet metal nut plate, then remove the shifter boot.



5. Remove the shift stick screw, then pull the shift stick straight off the shift lever.



6. Press the shift stick and adapter (item 3) onto the vehicle's shift lever and secure with the original bolt, then tighten the two set screws on the side of the adapter.





7. Reinstall the shifter boot, then carefully press the sheet metal nut plate onto the stud.



8. Reinstall the center console cover.



9. With its wrench flats facing down, run the lock nut (2) all the way down the shifter threads. Then run the shift knob (1) as far down the threads as it will go while keeping the B&M logo aligned as desired. Finally, secure the shift knob with the lock nut.



10. Reinstall the trim ring and shift knob on the transfer case shift lever, then snap the trim ring to the bottom of the knob to secure it to the lever.



**Congratulations, the installation of your B&M Manual Shift Stick and Knob is complete!**