

INSTALLATION INSTRUCTIONS

69-8612TFK TOYOTA 2006-17 Yaris L4-1.5L

TOOLS NEEDED:

Flat Blade Screw Driver
Phillips Screw Driver
Ratchet
Extension
10mm Socket
3mm Allen Wrench
10mm Wrench

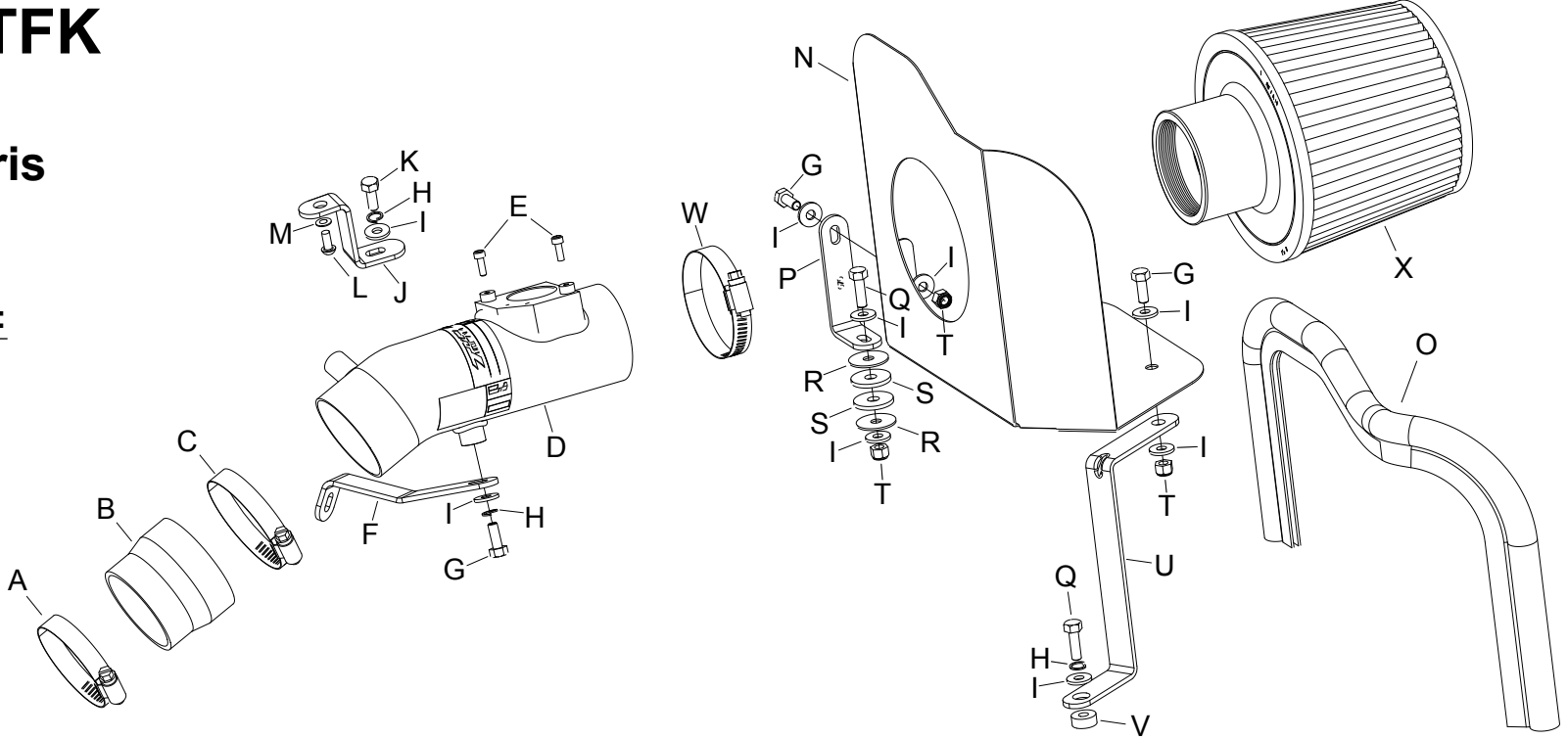

PARTS LIST:

Description	Qty.	Part #	Description	Qty.	Part #	Description	Qty.	Part #
A Hose Clamp #32	1	08507	I Washer; 1/4"IDx5/8"OD - SAE	9	08275	Q Bolt; M6-1.00x25MM, SS	2	07858
B Hose; 2-1/4" To 2-1/2"x2"L,	1	08476	J Bracket; Short "Z", FIN.	1	07958	R Washer; 1"Dx1/4 Hole Fender	2	08160
C Hose Clamp #36	1	08530	K Bolt; M6x1.00"x20MM Hex, SS	1	07795	S Washer; 1"x.300x.100 Rubber	2	21685
D Intake Tube	1	27537-1	L Bolt; M5-0.8x12MM B/H, SS	1	07734	T Nut; 6MM Nylock, Hex Head	3	07512
E Bolt; M4-0.07 8MM, A/H Cap, SS	2	07733	M Washer; 5MM Internal Star Cut	1	07724	U Bracket; "Z", FIN.	1	07925
F Bracket; "L", STL, FB/PC	1	06510	N Heat Shield	1	07361	V Spacer: .625"ODx.250"IDx.250"L	1	06555
G Bolt; 6MM-1.00x16MM, SS	3	07812	O Edge Trim	1	102495	W Hose Clamp #40	1	08554
H Washer; 1/4" Lock, ZN	3	08198	P Bracket; "L", FIN	1	07093	X Air Filter	1	RU-5174

If you need any assistance please call 1-800-858-3333 to speak with a representative in our Customer Service Center before returning the product.

NOTE: FAILURE TO FOLLOW INSTALLATION INSTRUCTIONS AND NOT USING THE PROVIDED HARDWARE MAY DAMAGE THE INTAKE TUBE, THROTTLE BODY AND ENGINE.

TO START:

1. Turn off the ignition and disconnect the negative battery cable.
NOTE: Disconnecting the negative battery cable erases pre-programmed electronic memories. Write down all memory settings before disconnecting the negative battery cable. Some radios will require an anti-theft code to be entered after the battery is reconnected. The anti-theft code is typically supplied with your owner's manual. In the event your vehicles' anti-theft code cannot be recovered, contact an authorized dealership to obtain your vehicles anti-theft code.



2. Depress the locking tab and remove the mass air sensor connector. Remove the clips that secure the mass air sensor harness to the stock air box.



3. Pull the vacuum switching valve and bracket assembly from the stock intake tube. Un-clip the vacuum hose from the stock intake tube.



4. Loosen the spring clamp that secures the crank case vent tube to the stock intake tube as shown. Remove the crank case vent tube from the stock intake tube.
NOTE: The spring clamp will be re-used.



5. Loosen the hose clamp that secures the stock intake tube to the throttle body as shown. Remove the stock intake tube from the throttle body.



6. Release the two spring clamps that secure the upper air box assembly to the lower air box assembly as shown.



7. Remove the upper air box, stock intake tube, and air filter assembly as shown.

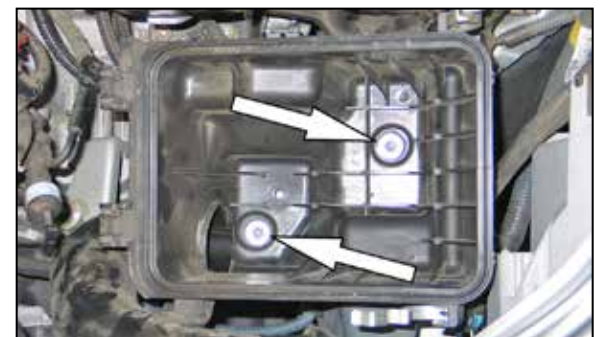

8. Remove the two bolts that secure the lower air box assembly as shown.



9. Remove the lower air box assembly as shown.
NOTE: K&N Engineering, Inc., recommends that customers do not discard factory air intake.



10. Remove the lower air box grommet as shown.



11. Remove the lower inboard nut securing the throttle body to the manifold as shown.
NOTE: The nut will be re-used in the next step.



12. Install bracket (#06510) onto the throttle body stud and secure with the nut removed in the previous step.



13. Install silicone hose (#08476) onto the throttle body and secure with the provided hose clamp as shown.



14. Install the provided edge trim onto the heat shield as shown.
NOTE: Some trimming of the edge trim may be necessary.



15. Install bracket (# 07925) onto the heat shield with the provided hardware as shown.



16. Install bracket (#07093) onto the lower air box support bracket with the provided hardware as shown.
NOTE: Do not completely tighten at this time.



17. Install the heat shield assembly and secure it with the provided hardware as shown.



18. Remove the two screws that secure the mass air sensor to the upper air box assembly, then remove the mass air sensor as shown.



19. Install the mass air sensor into the K&N® intake tube with the provided hardware as shown.



20. Install the K&N® intake tube into the silicone hose at the throttle body and align with the tube bracket and heat shield. Secure with the provided hardware as shown.



21. Remove the screw that secures the vacuum switching valve to the bracket. Un-clip the wiring harness from the bracket as shown.



22. Install bracket (#07958) onto the vacuum switching valve with the provided hardware as shown.



23. Remove the bolt securing the radiator fill neck to the radiator fill neck support (as shown).



24. Install the vacuum switching valve assembly onto the radiator fill neck support with the provided hardware as shown.



25. Install the crank case vent line onto the K&N® intake tube using the spring clamp removed in step # 4 (as shown).



26. Re-connect the mass air sensor electrical connector as shown.



27. Install the K&N® air filter as shown.
NOTE: Drycharger® air filter wrap; part # RX-4990DK is available to purchase separately. To learn more about Drycharger® filter wraps or look up color availability please visit <http://www.knfilters.com>.



28. Reconnect the vehicle's negative battery cable. Double check to make sure everything is tight and properly positioned before starting the vehicle.

29. It will be necessary for all K&N® high flow intake systems to be checked periodically for realignment, clearance and tightening of all connections. Failure to follow the above instructions or proper maintenance may void warranty.

ROAD TESTING:

1. Start the engine with the transmission in neutral or park, and the parking brake engaged. Listen for air leaks or odd noises. For air leaks secure hoses and connections. For odd noises, find cause and repair before proceeding. This kit will function identically to the factory system except for being louder and much more responsive.

2. Test drive the vehicle. Listen for odd noises or rattles and fix as necessary.

3. If road test is fine, you can now enjoy the added power and performance from your kit.

4. K&N Engineering, Inc., requires cleaning the intake system's air filter element every 100,000 miles. When used in dusty or off-road environments, our filters will require cleaning more often. We recommend that you visually inspect your filter once every 25,000 miles to determine if the screen is still visible. When the screen is no longer visible some place on the filter element, it is time to clean it. To clean and re-oil, purchase our filter Recharger® service kit, part number 99-5050 or 99-5000 and follow the easy instructions.

**LEGAL IN CALIFORNIA ONLY FOR RACING VEHICLES
WHICH MAY NEVER BE USED, REGISTERED
OR LICENSED FOR USE UPON A HIGHWAY.**

See knfilters.com for CARB status on each part for a specific vehicle